

Exercise 1.

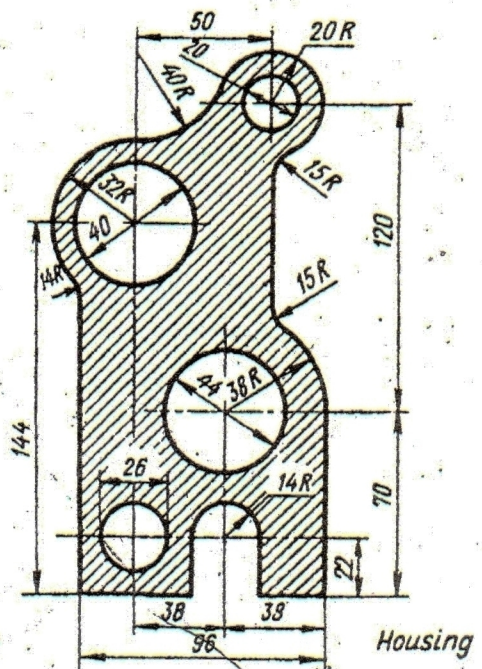

Exercise 2

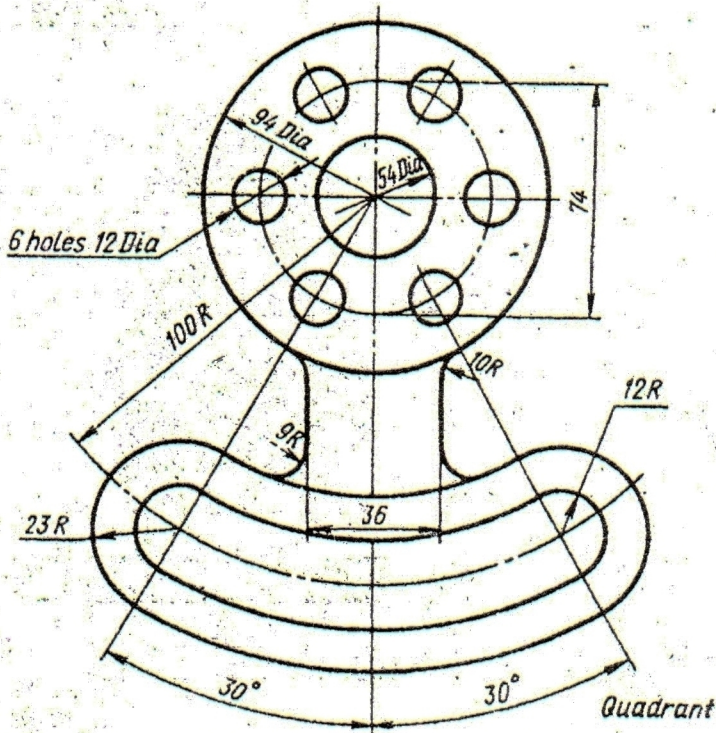
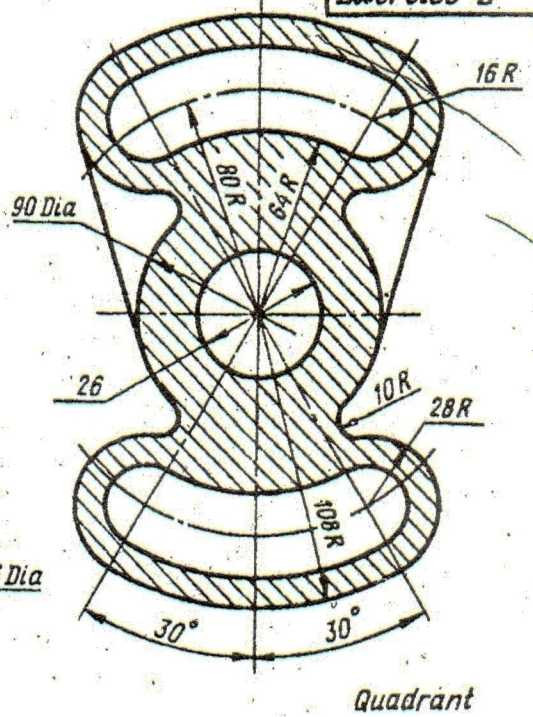
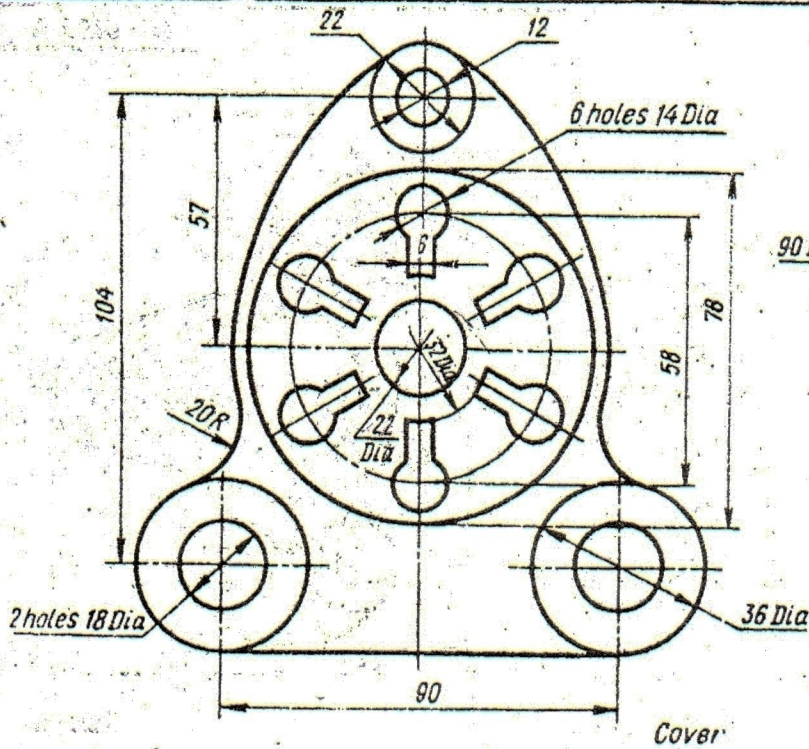

Exercise 3

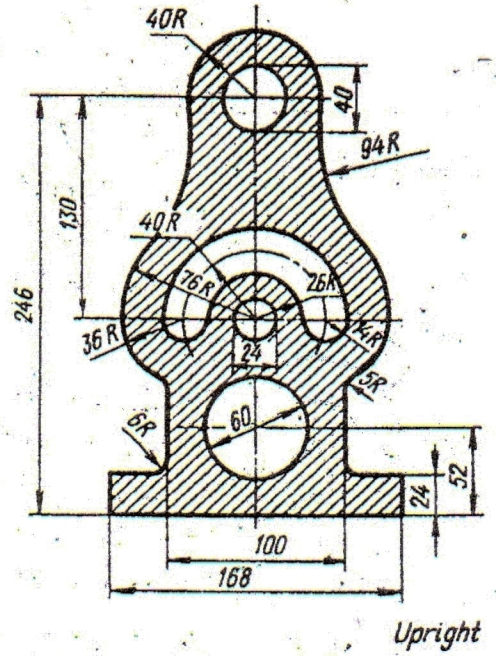
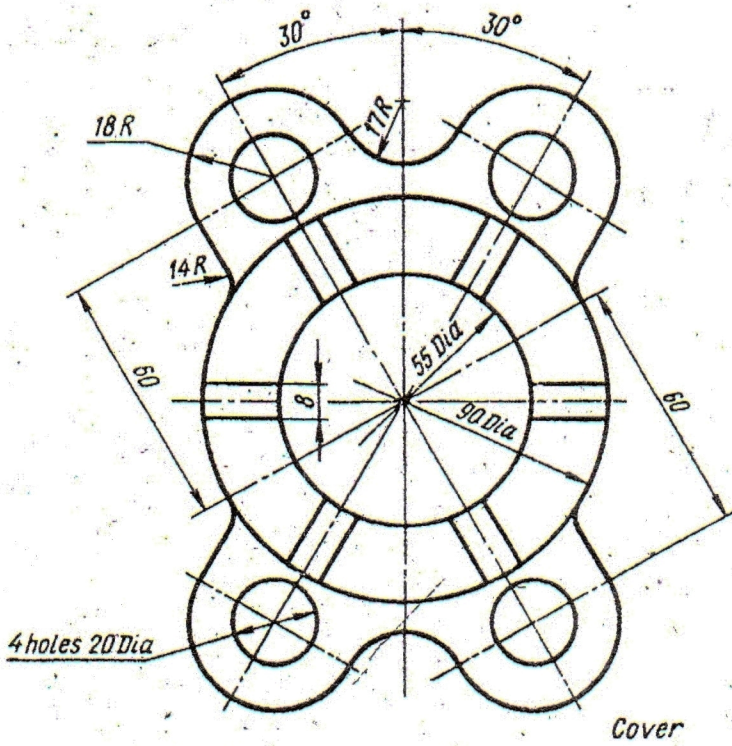

Exercise 4

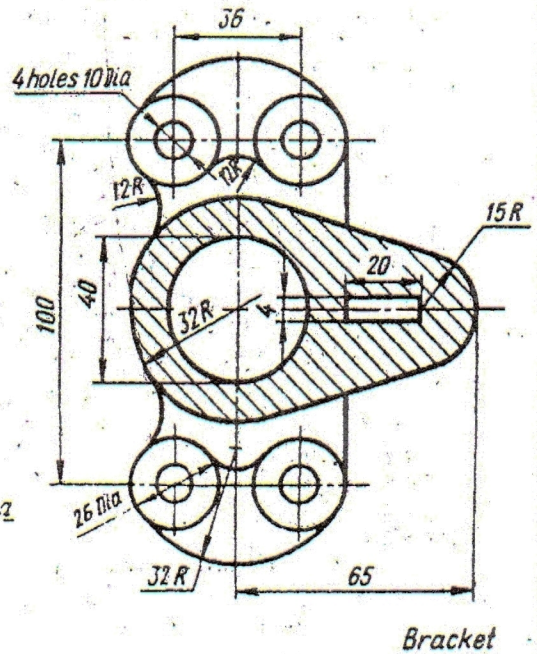
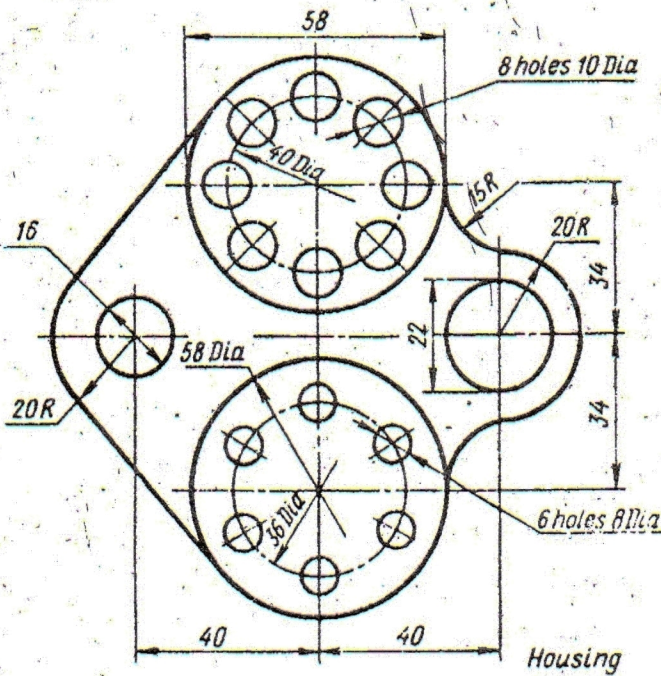

Exercise 5.

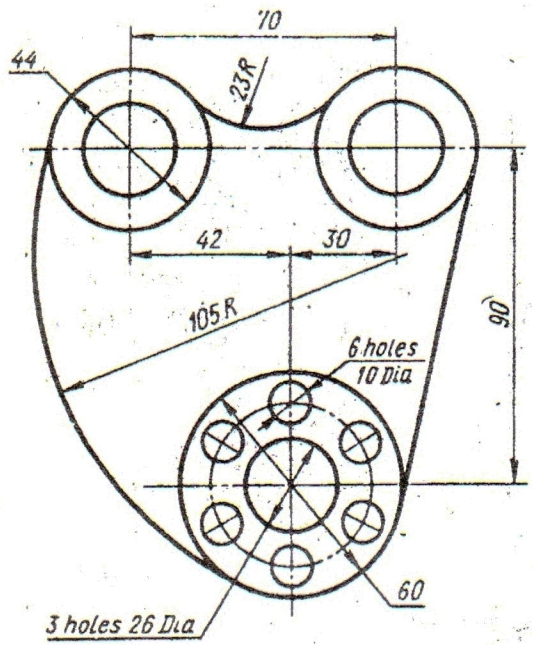

Eye

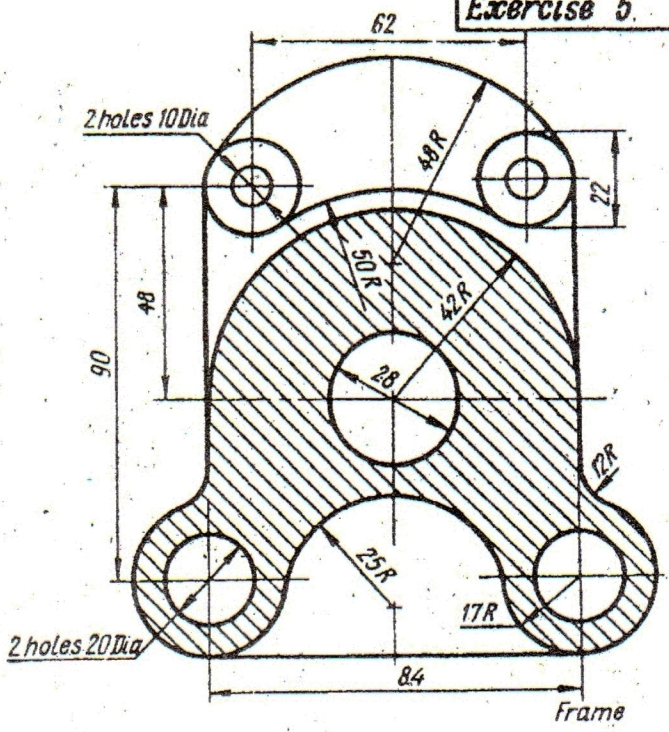

Frame

Exercise 6.

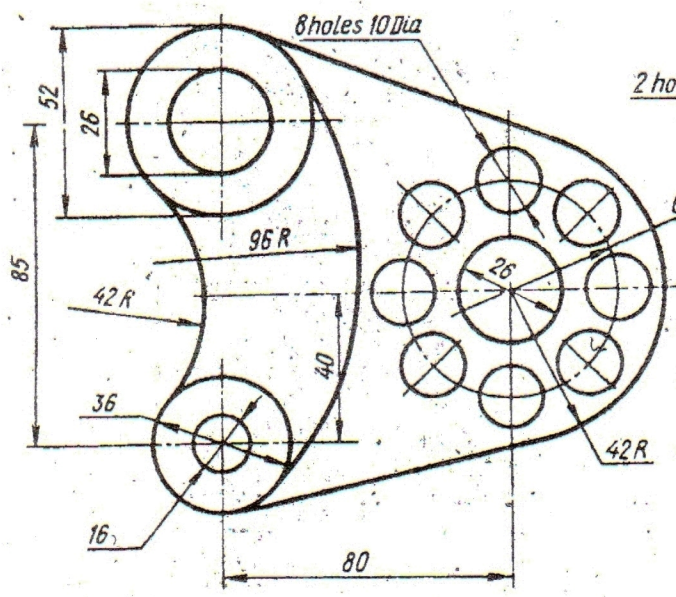

Plate

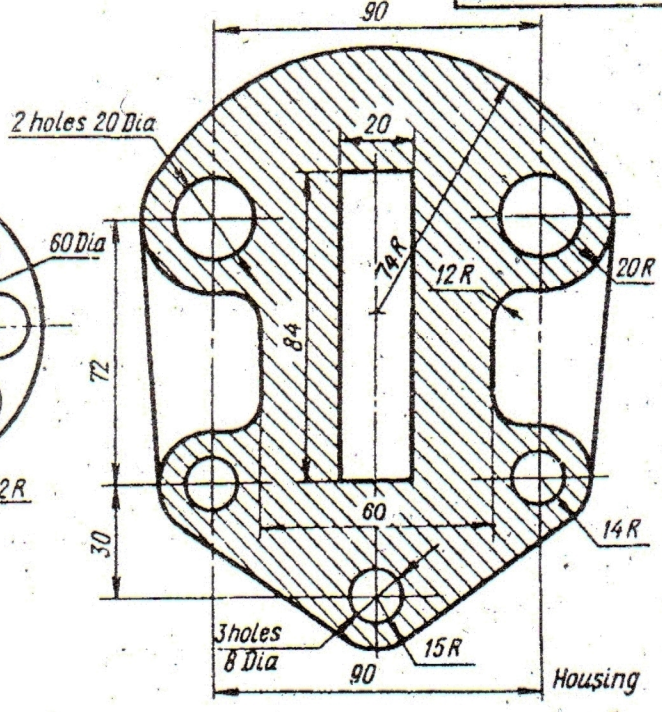

Housing

Exercise 7

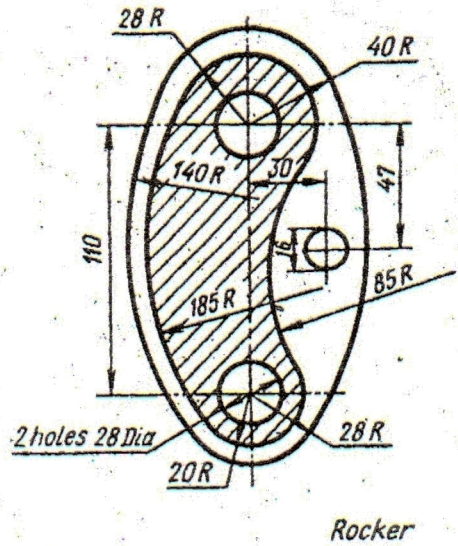
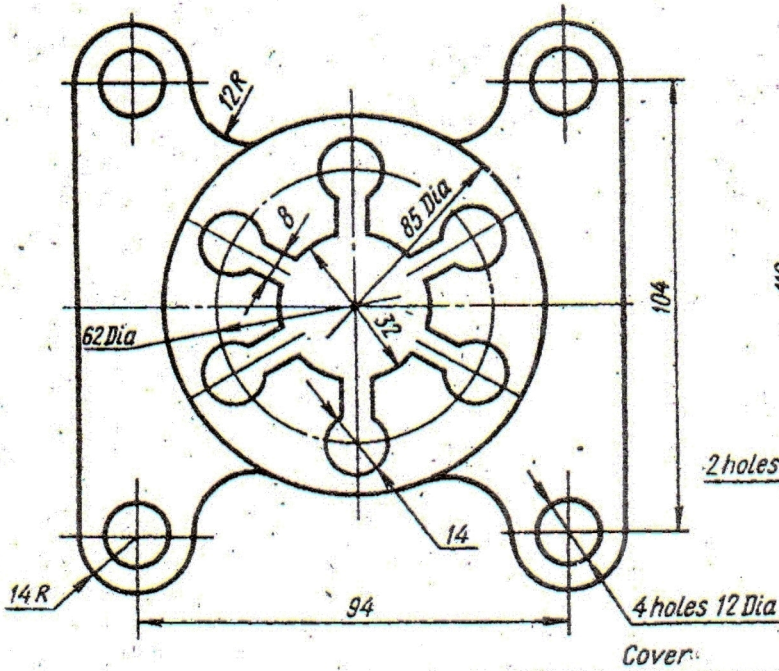

Exercise 8

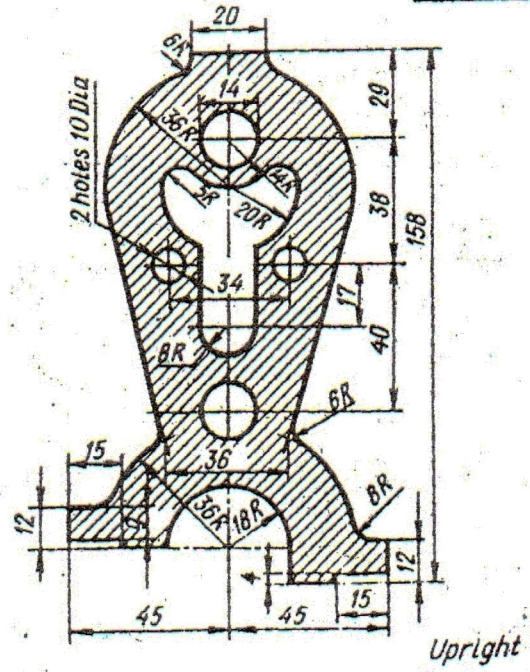
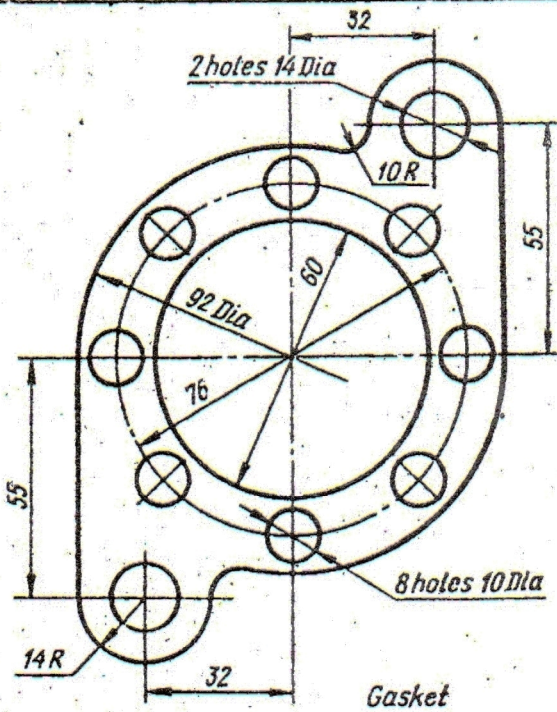

Exercise 9

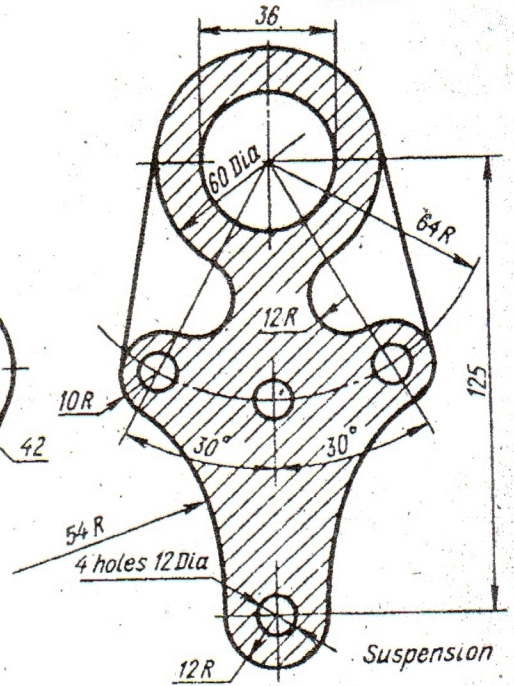
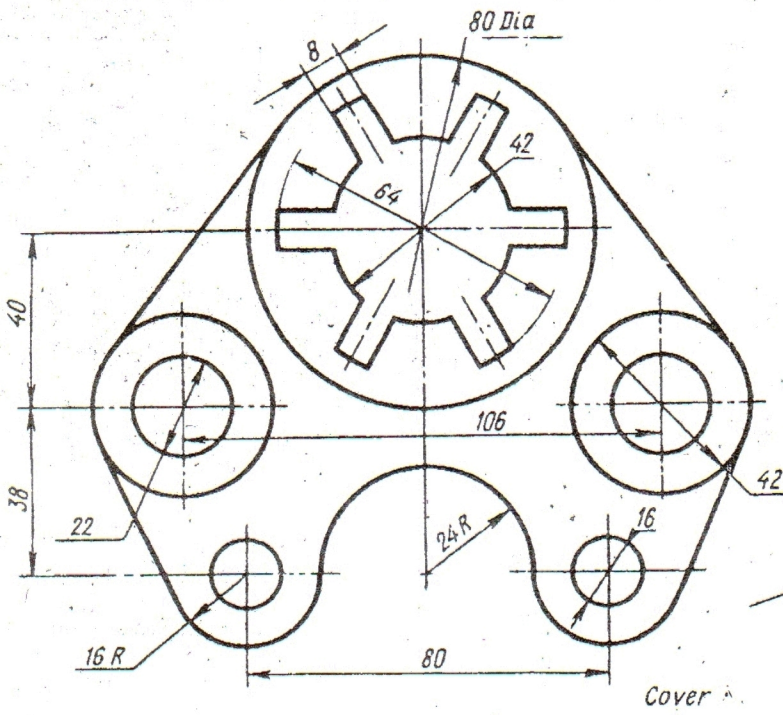

Exercise 10

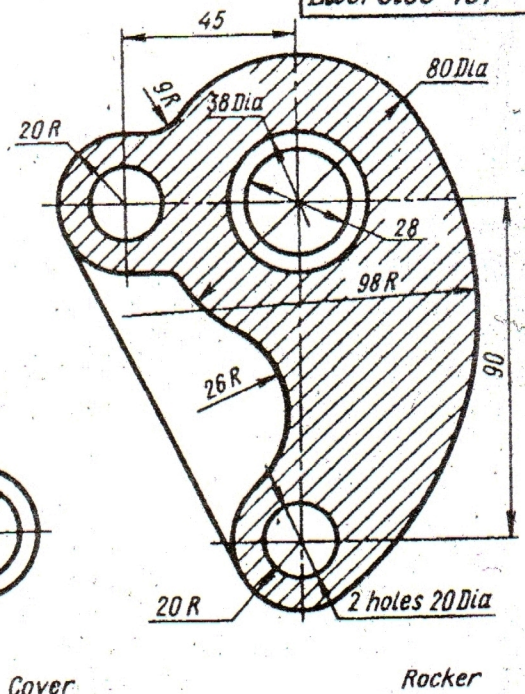
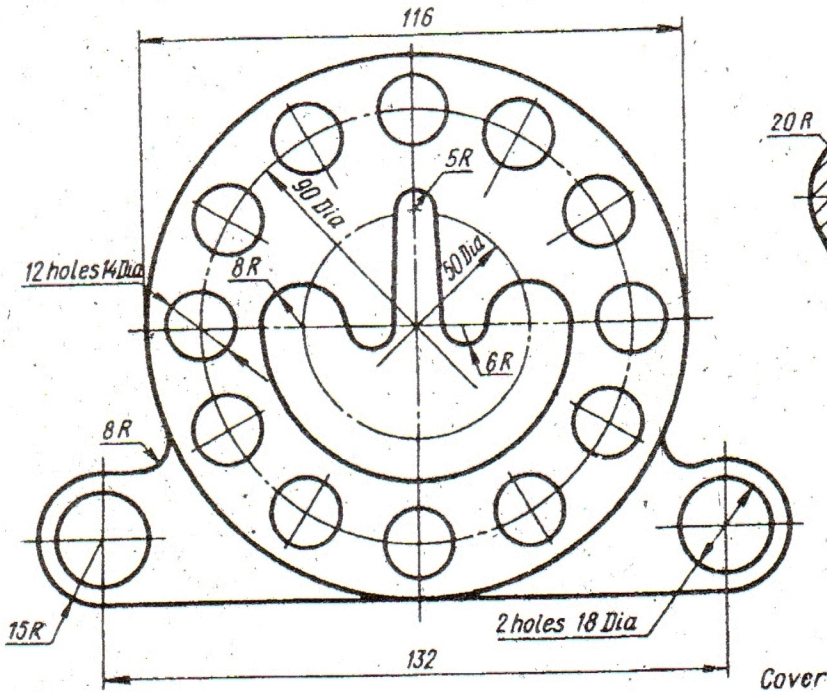

Exercise 11.

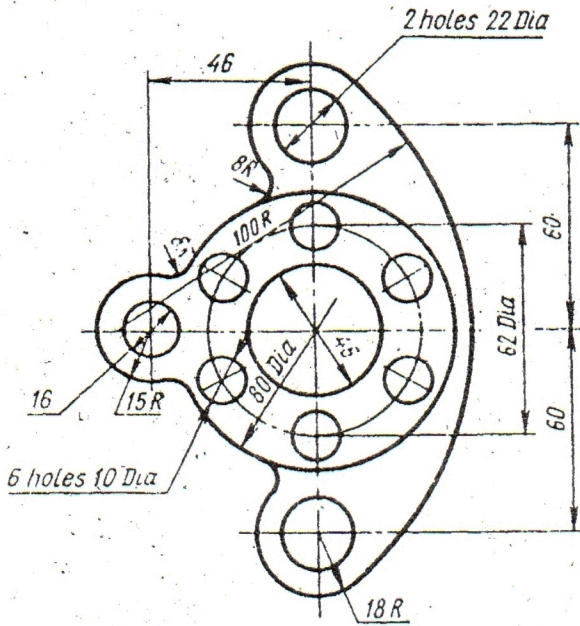

Bracket

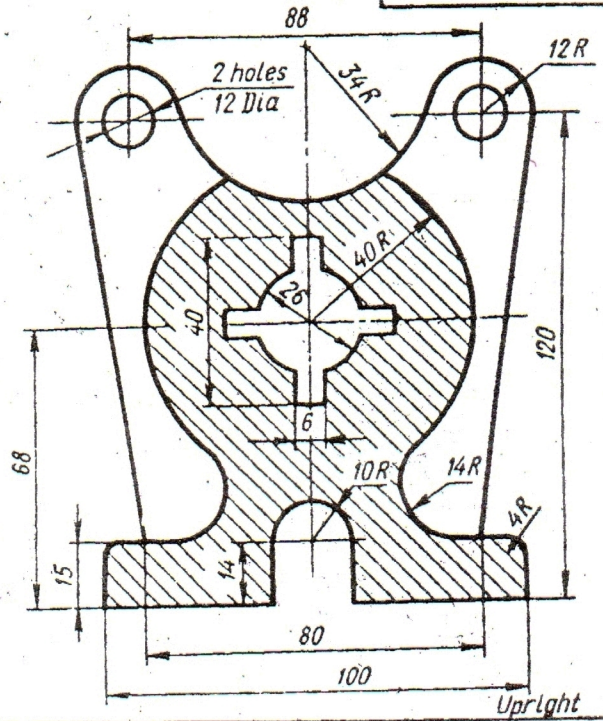

Upright

Exercise 12.

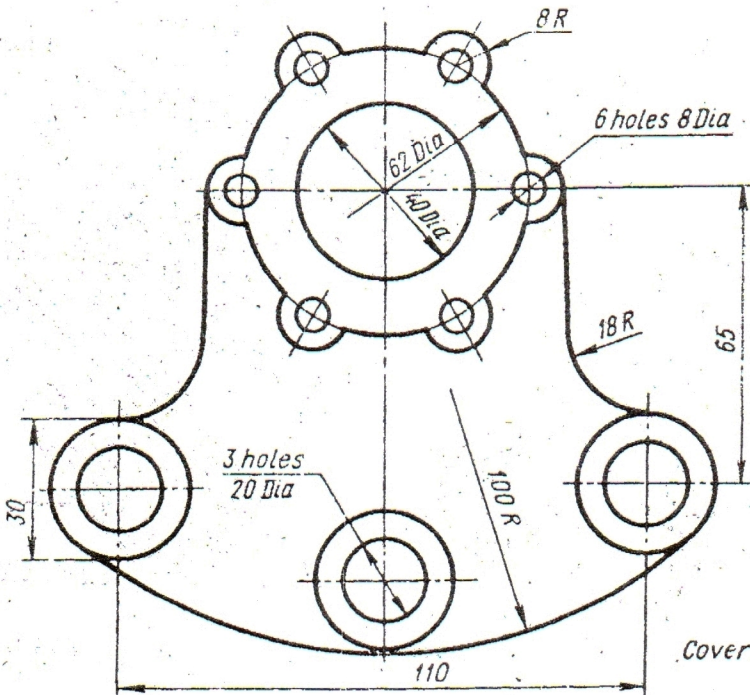

Cover

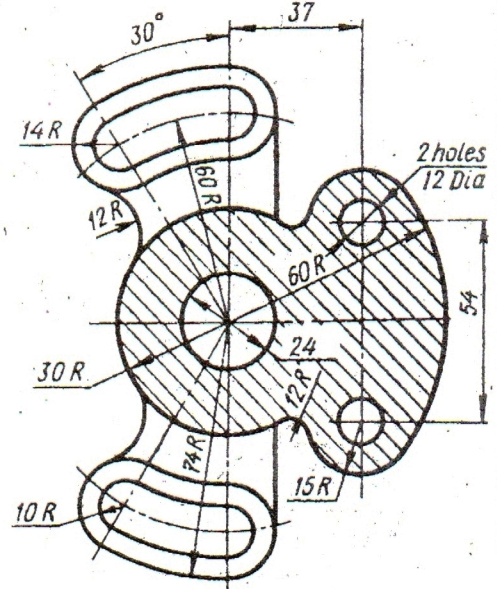

Housing

Exercise 13.

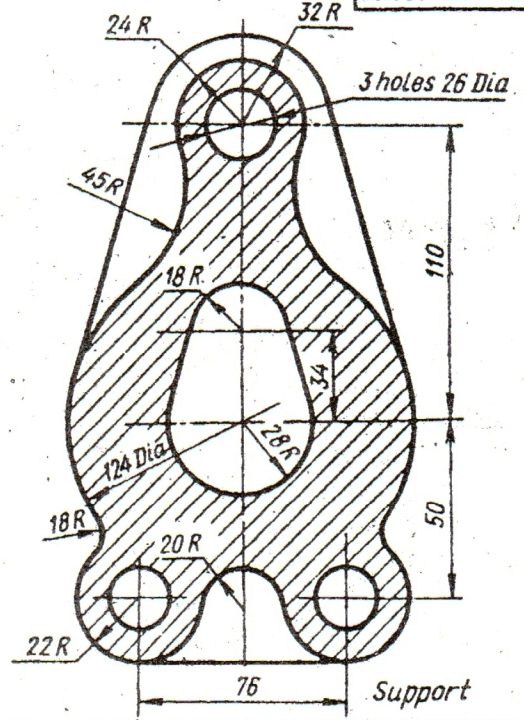
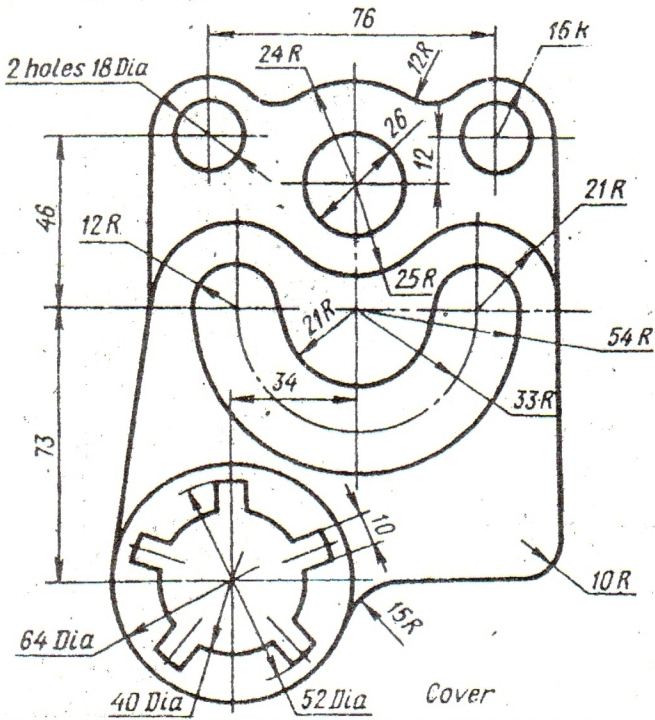

Exercise 14.

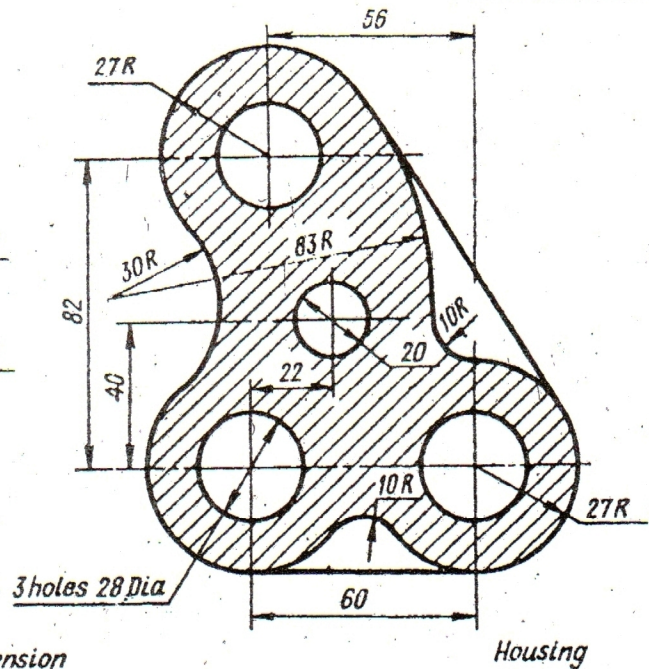
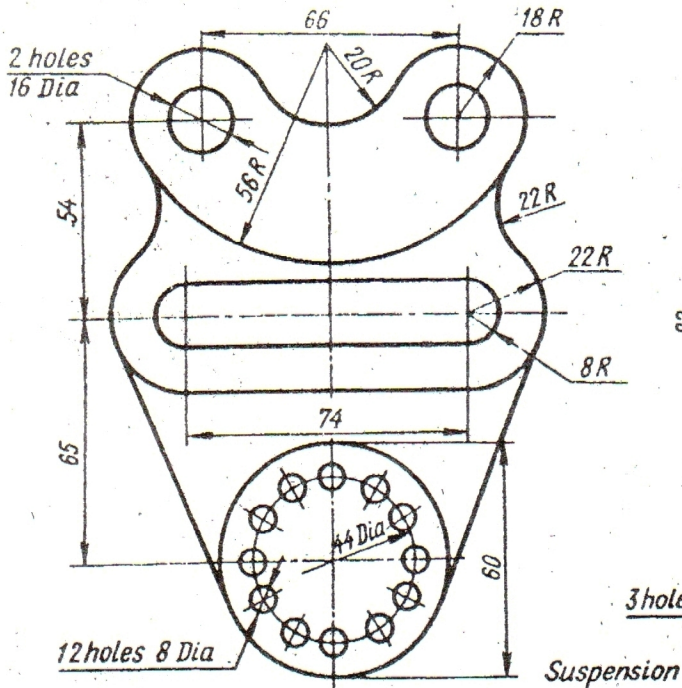

Exercise 15

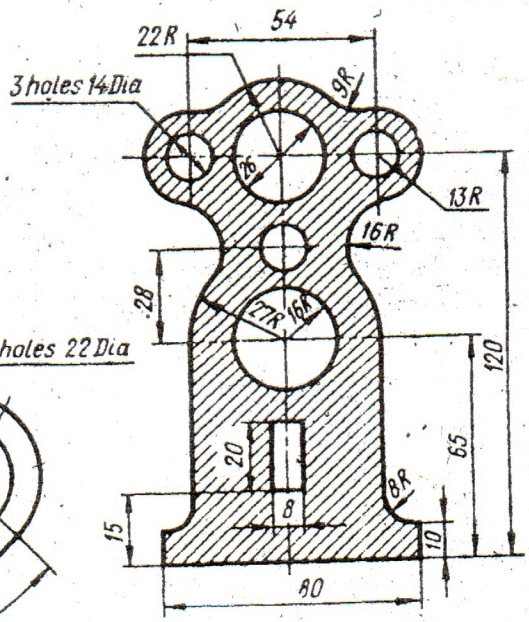
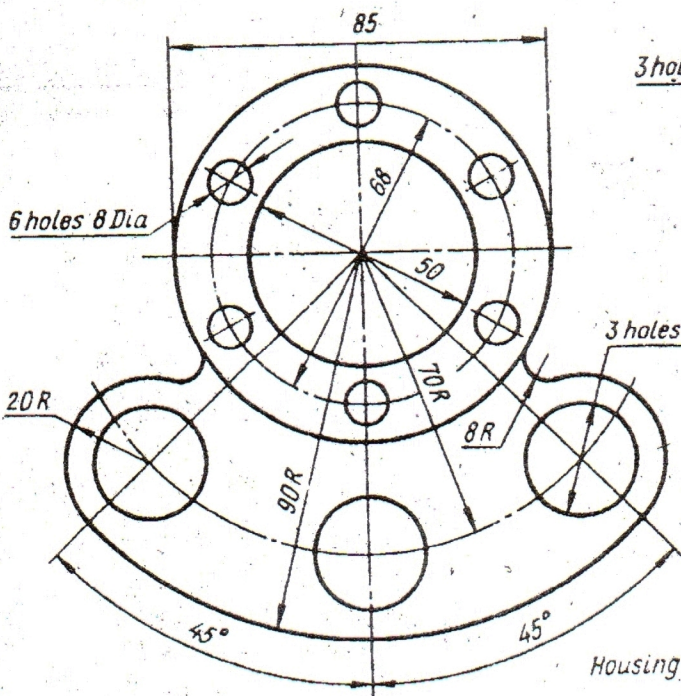

Housing

Upright

Exercise 16

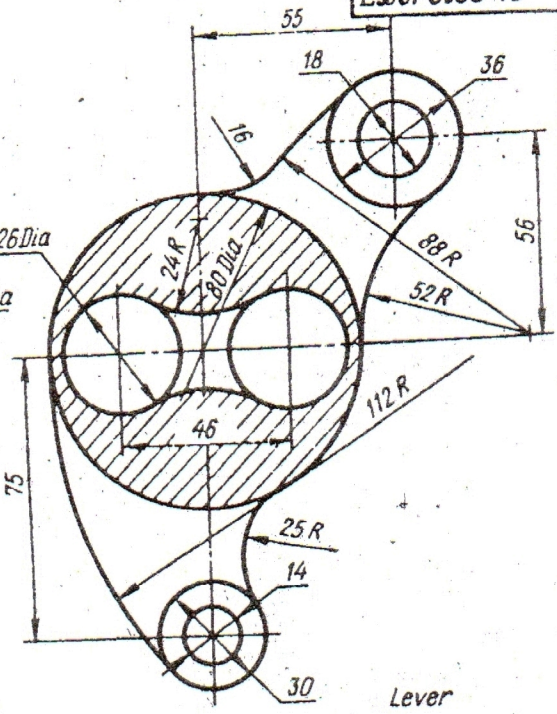
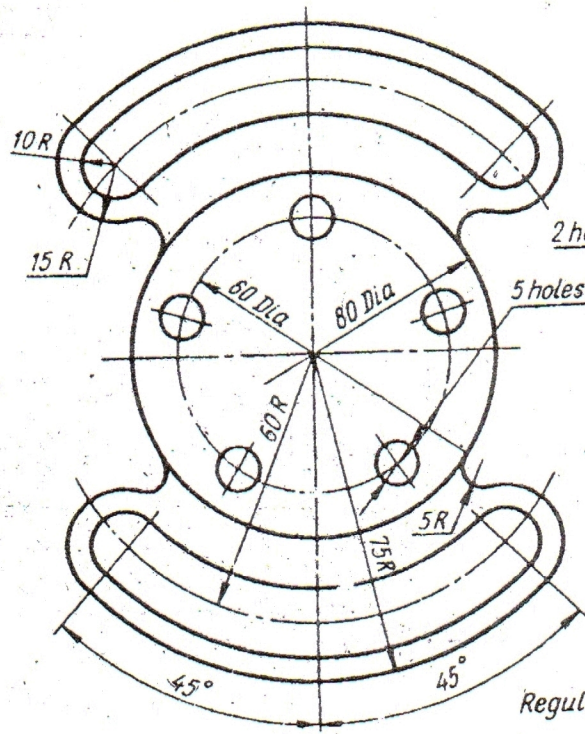

Regulator

Lever

Exercise 17

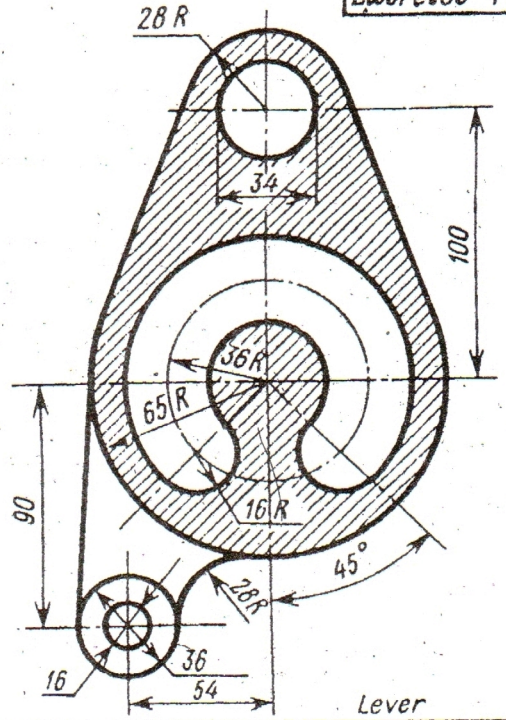
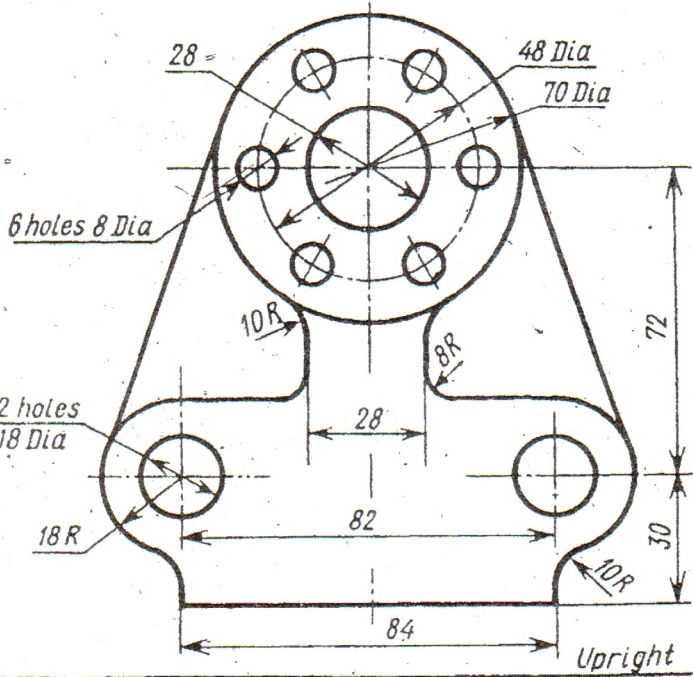

Exercise 18

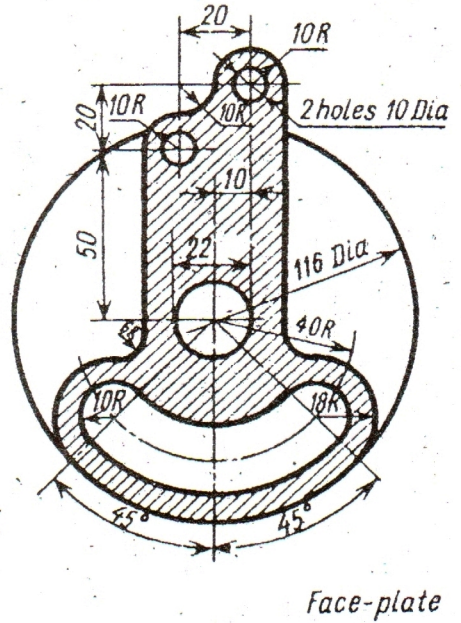
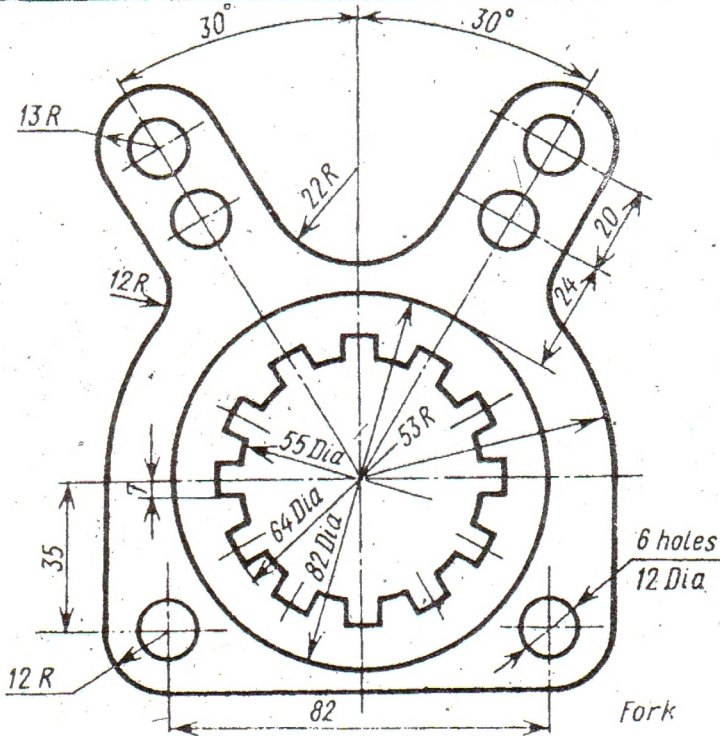

Exercise 19

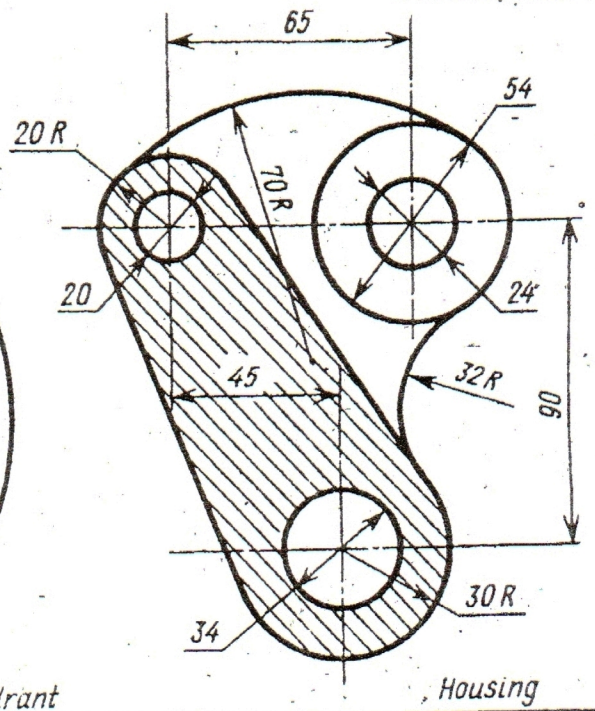
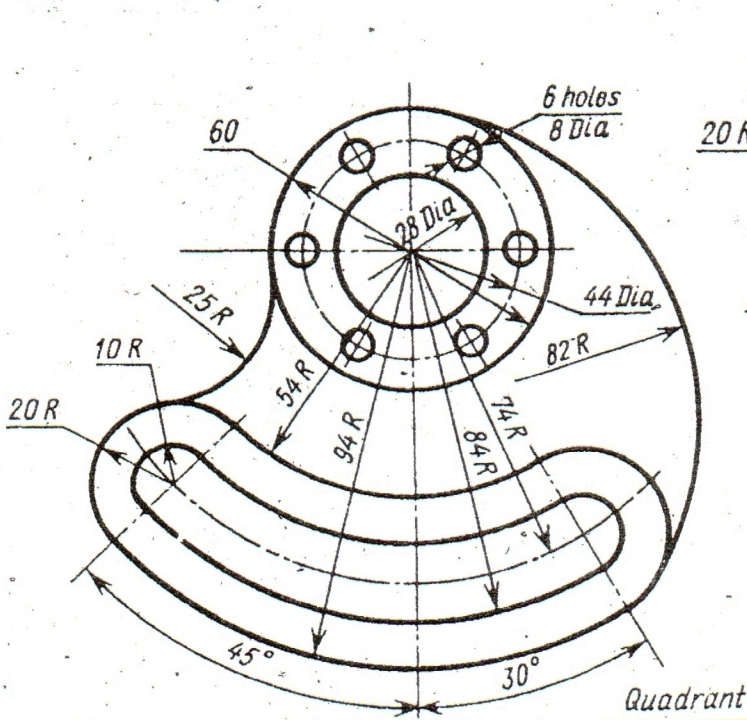

Exercise 20

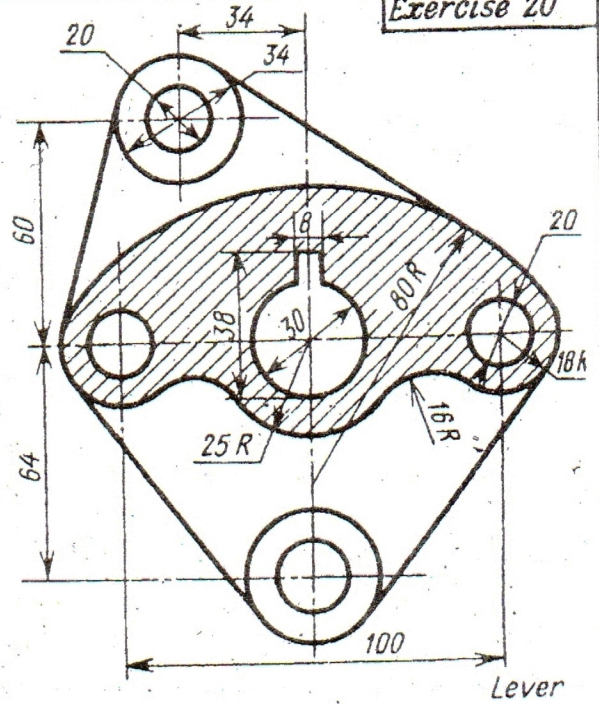
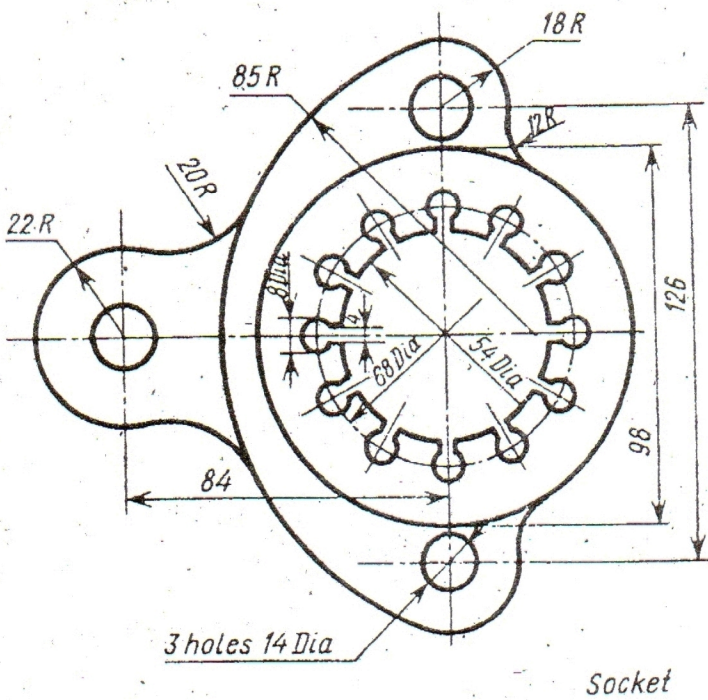

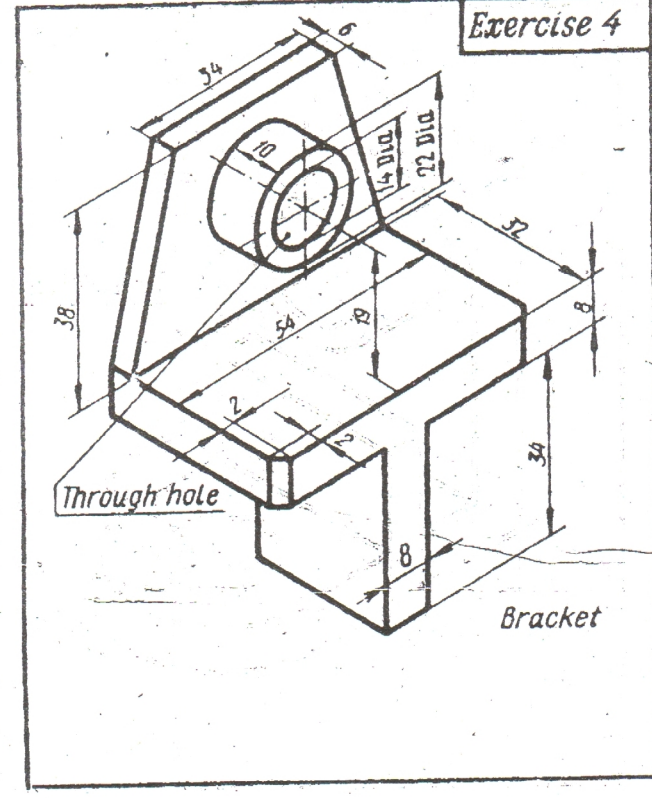
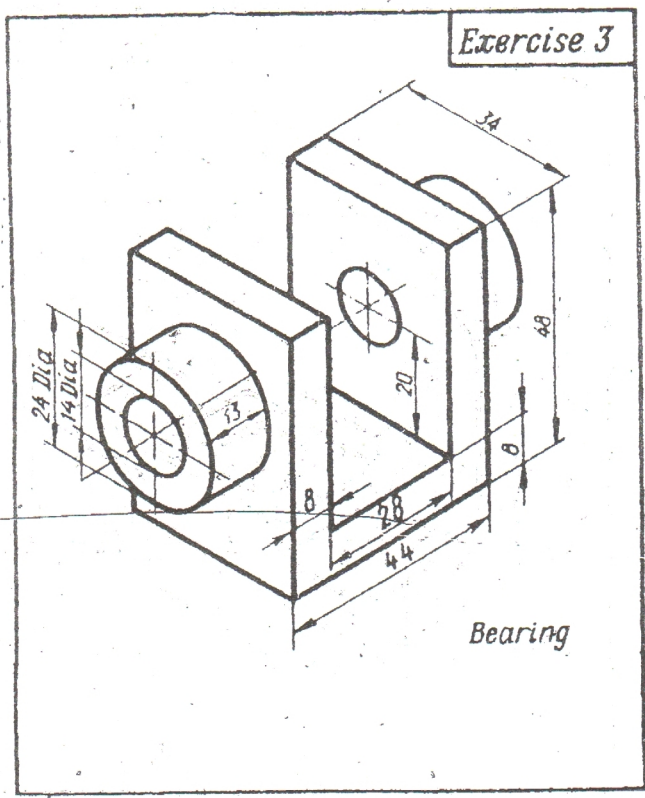
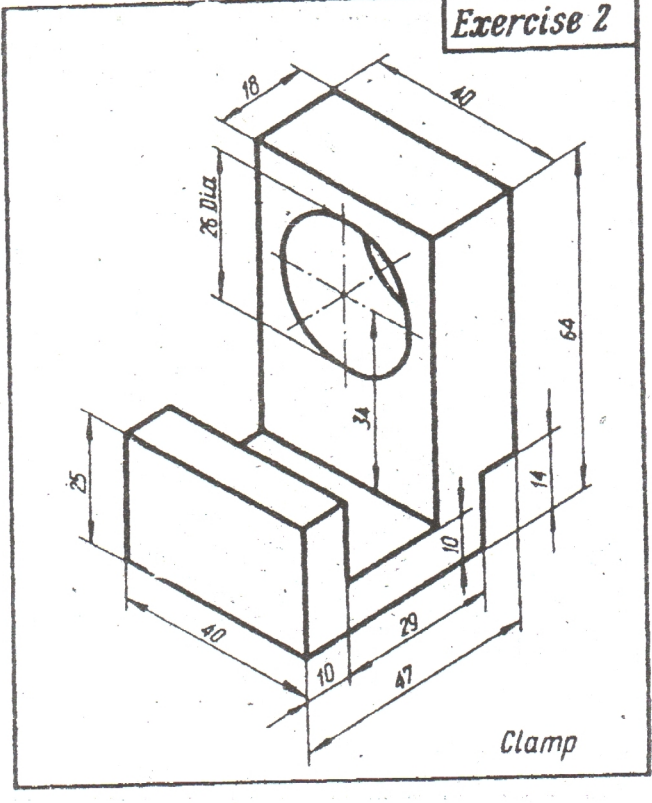
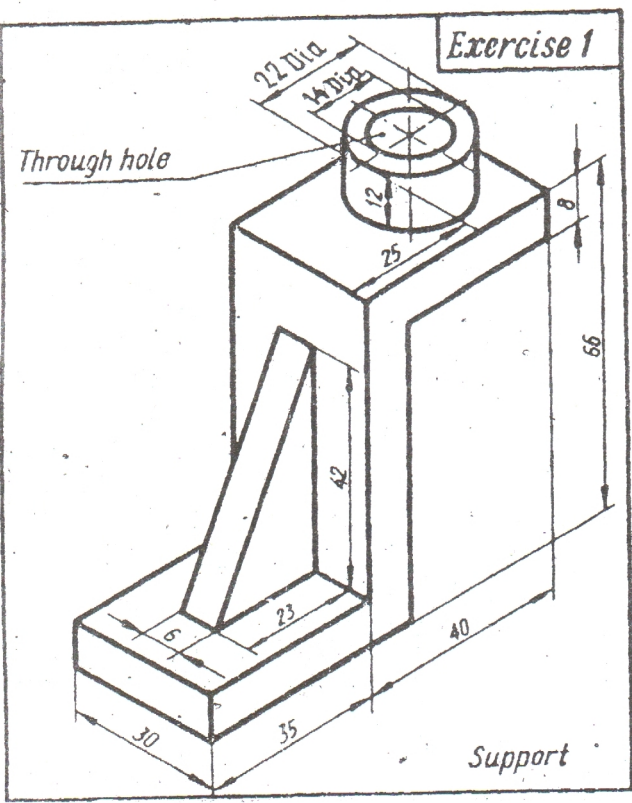

Exercise 5

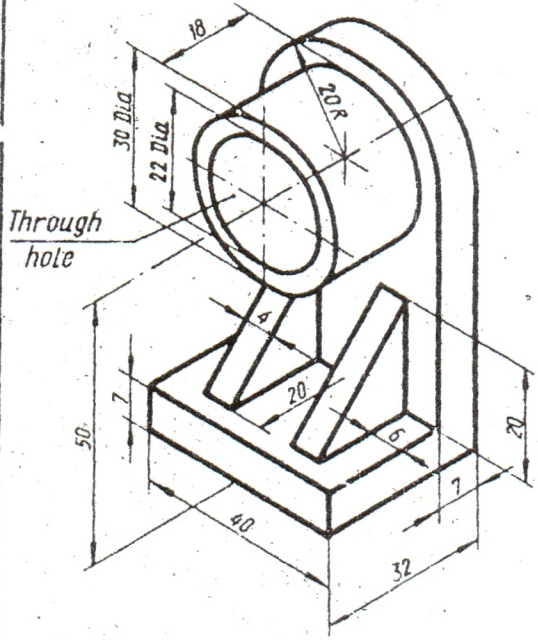

Bearing

Exercise 6

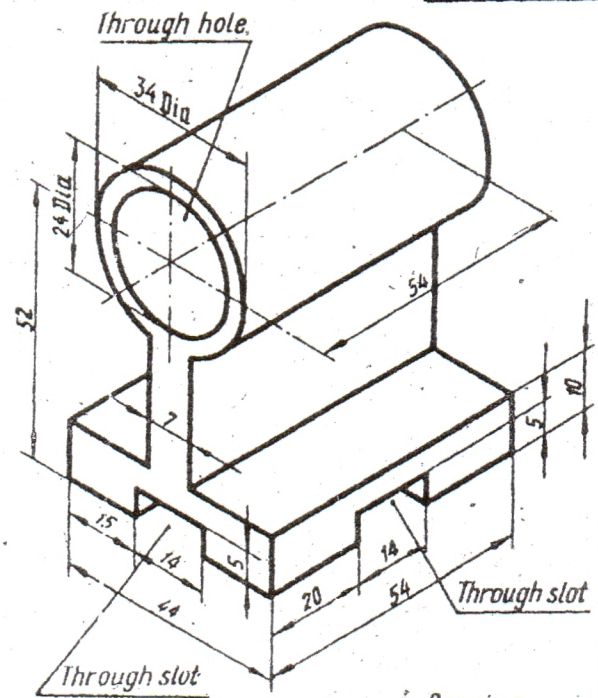

Bearing

Exercise 7

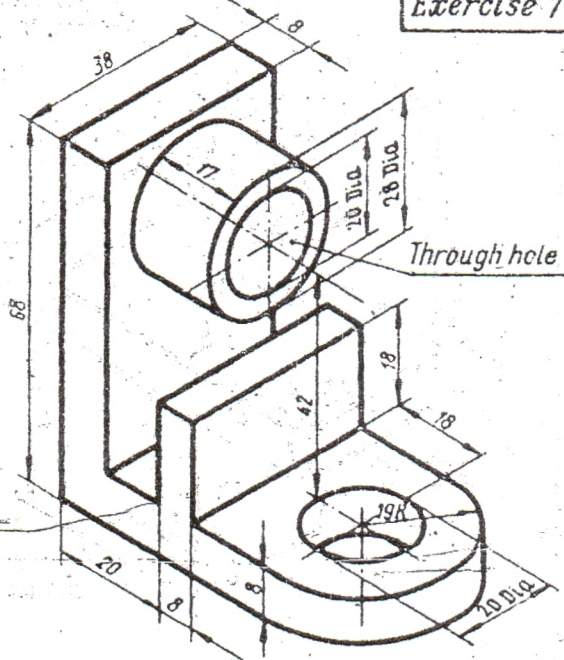

Bracket

Exercise 8

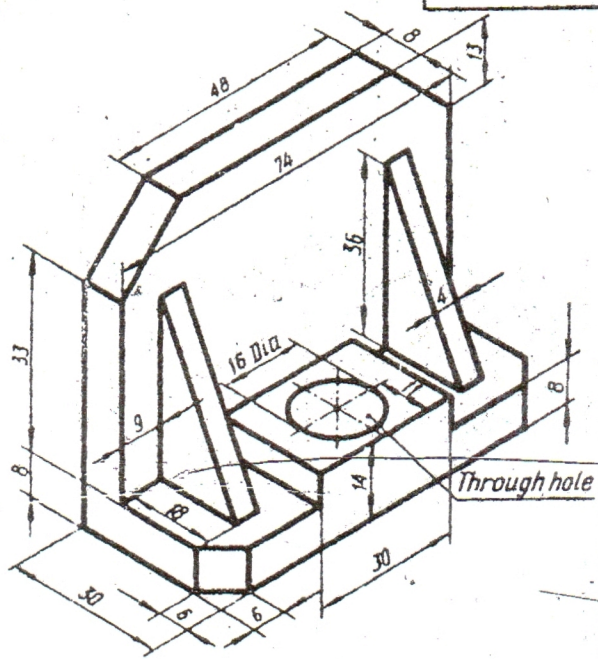

Body

Exercise 9

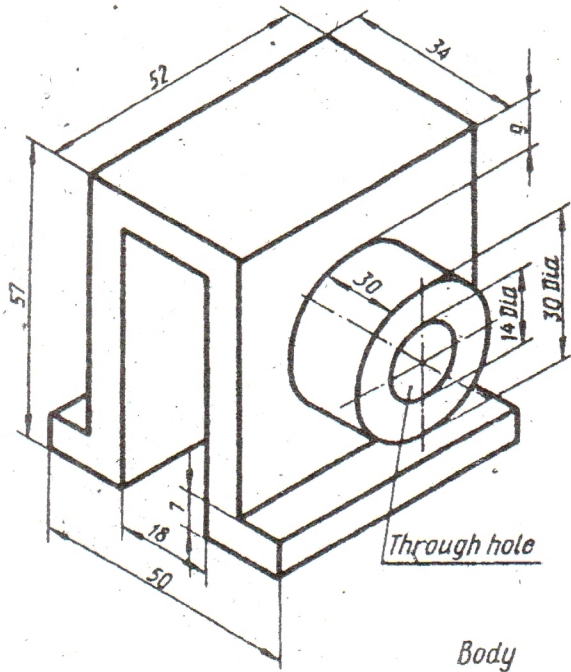

Body

Exercise 10

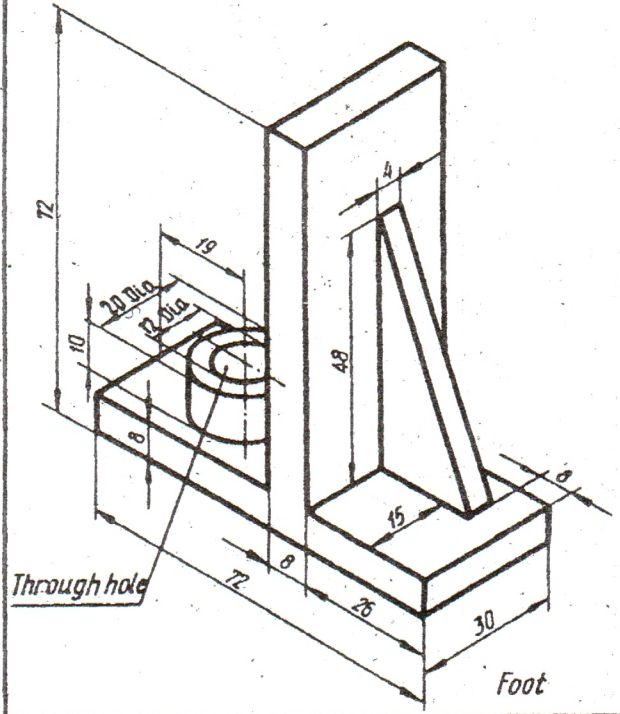

Foot

Exercise 11

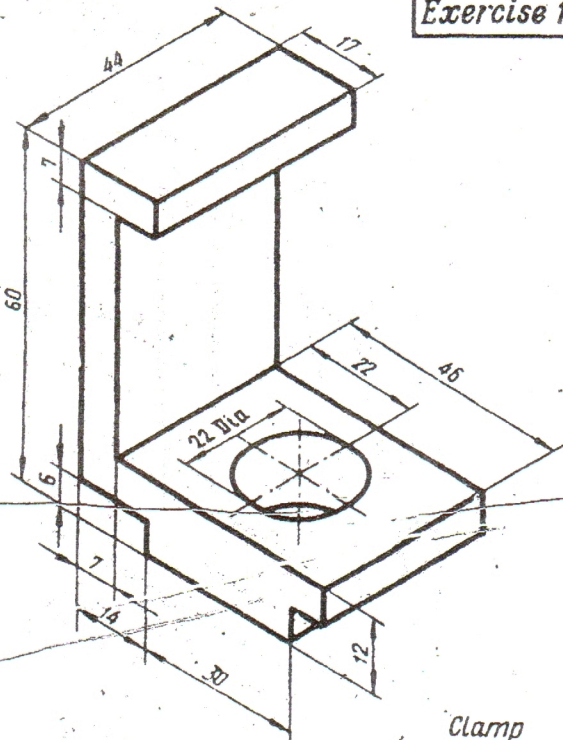

Clamp

Exercise 12

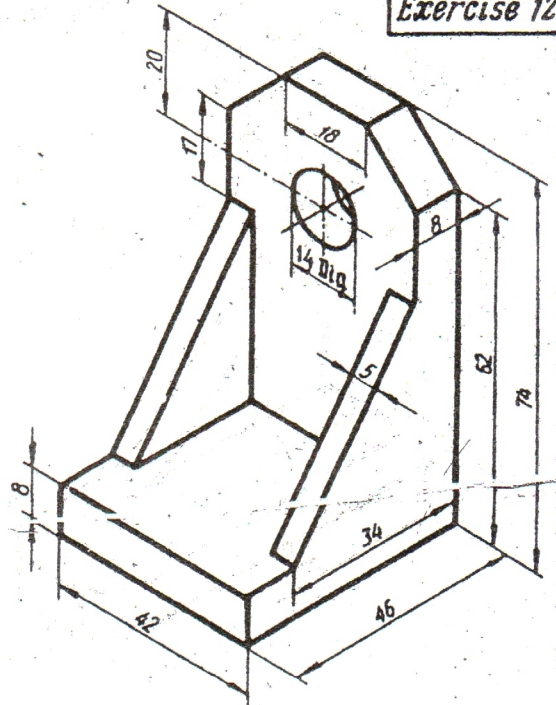

Angle

Exercise 13

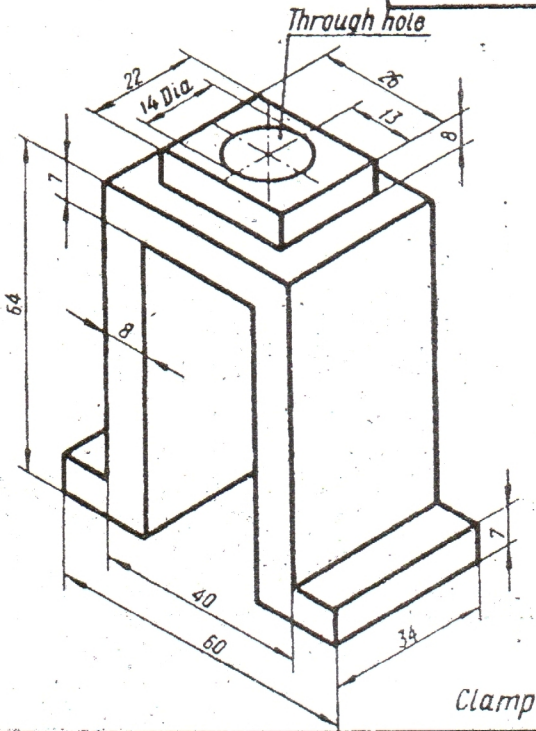

Exercise 14

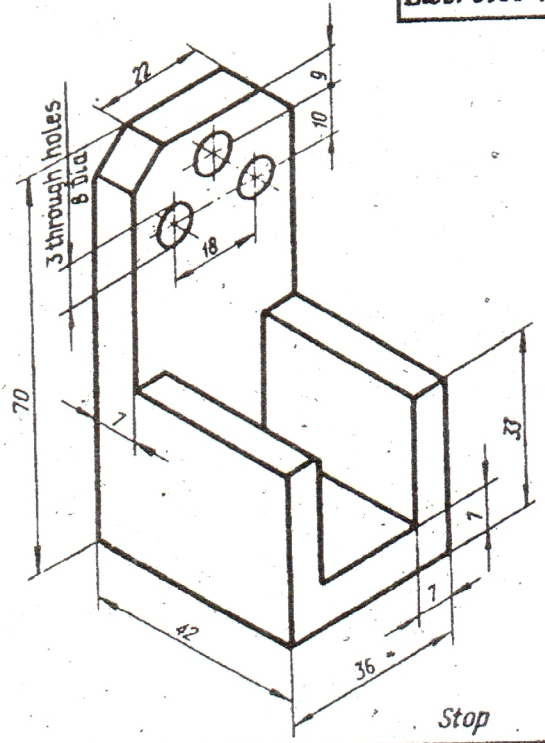

Exercise 15

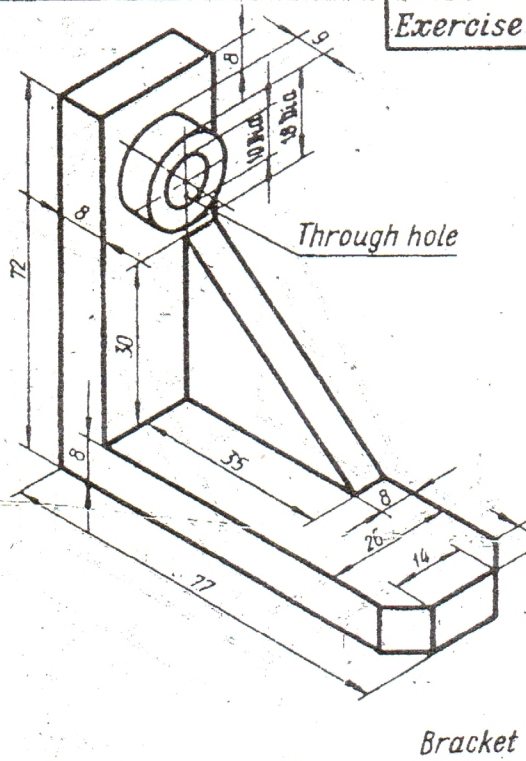

Exercise 16

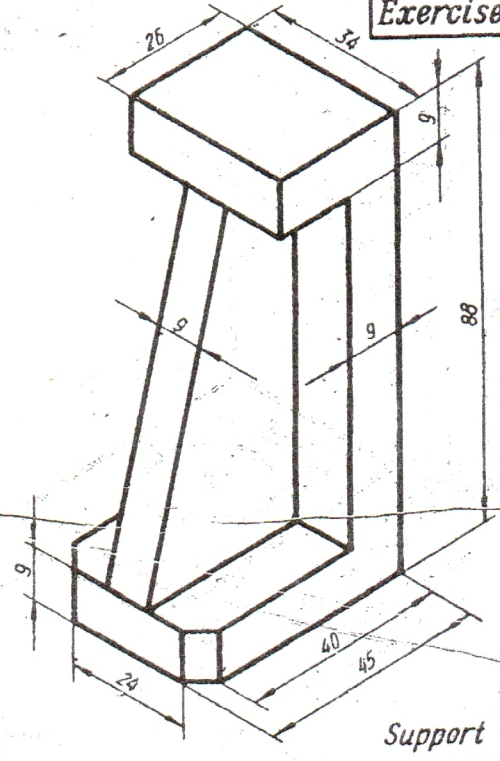

Exercise 17

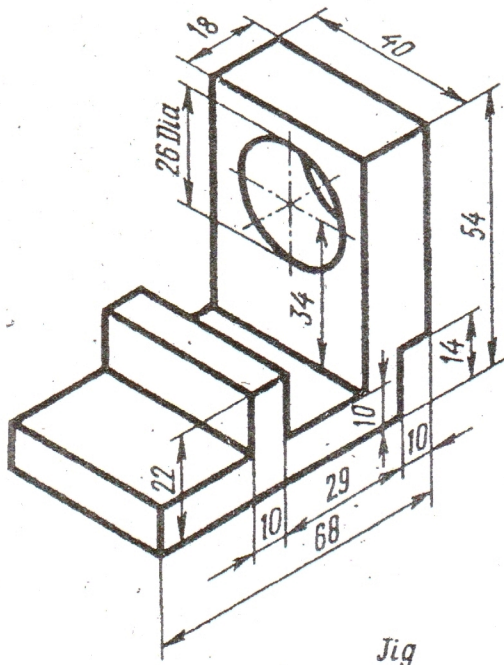

Jig

Exercise 18

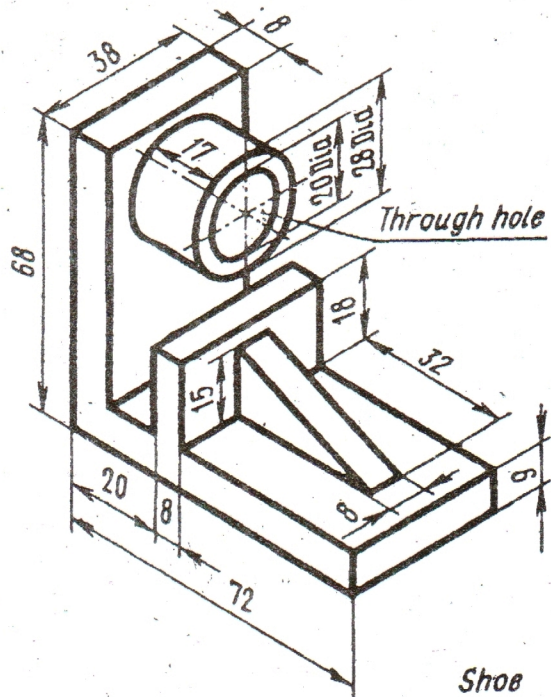

Shoe

Exercise 19

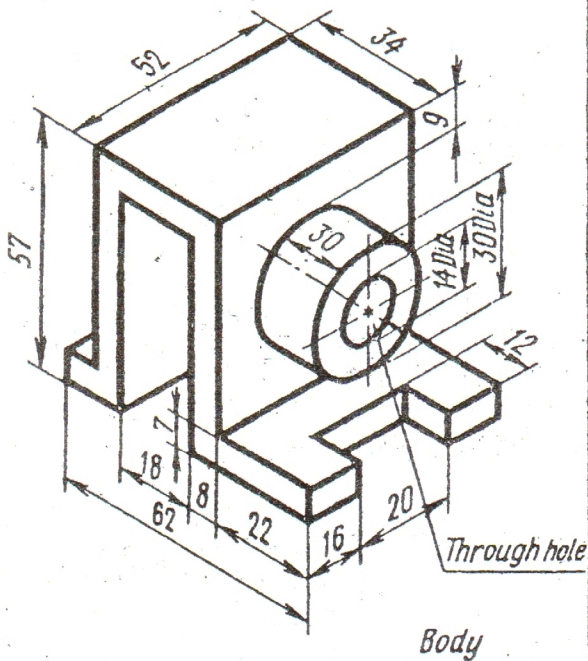

Body

Exercise 20

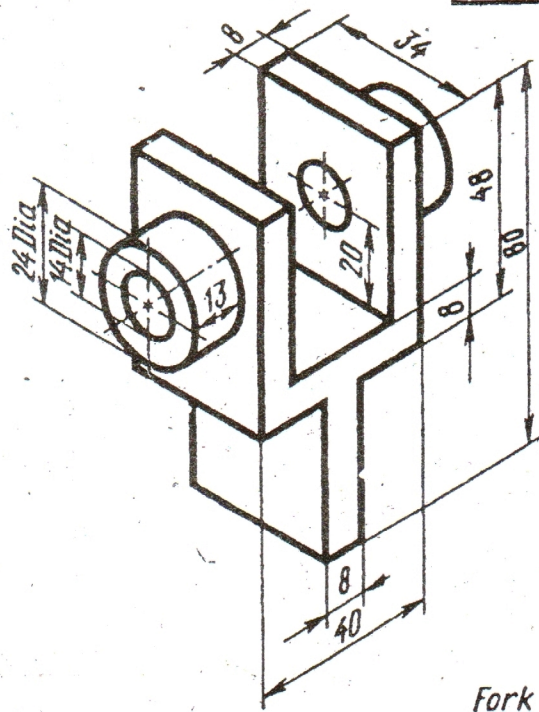

Fork

Exercise 1

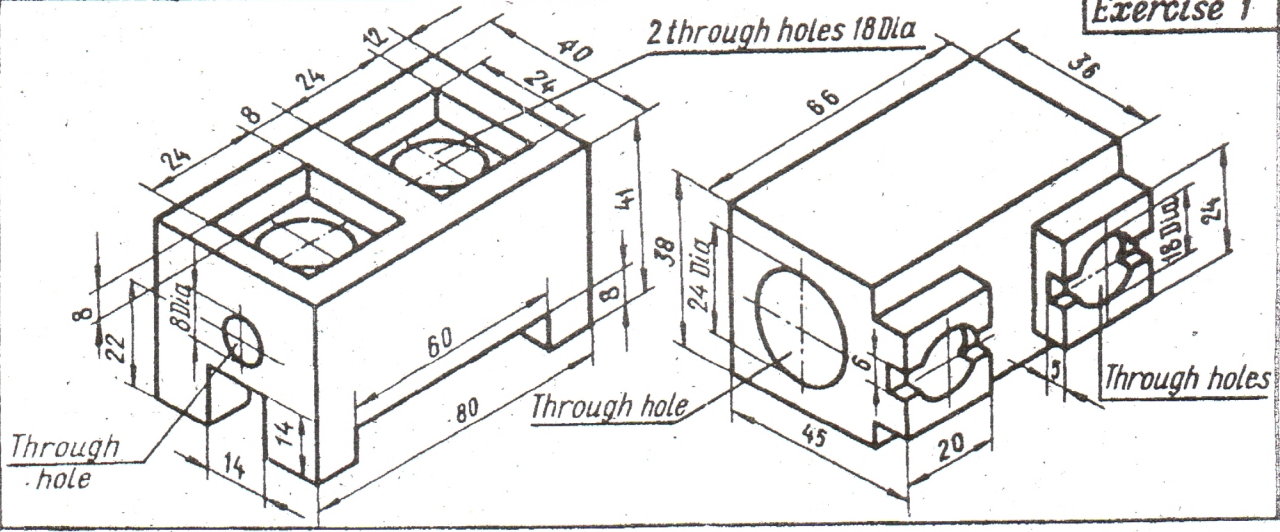

Exercise 2

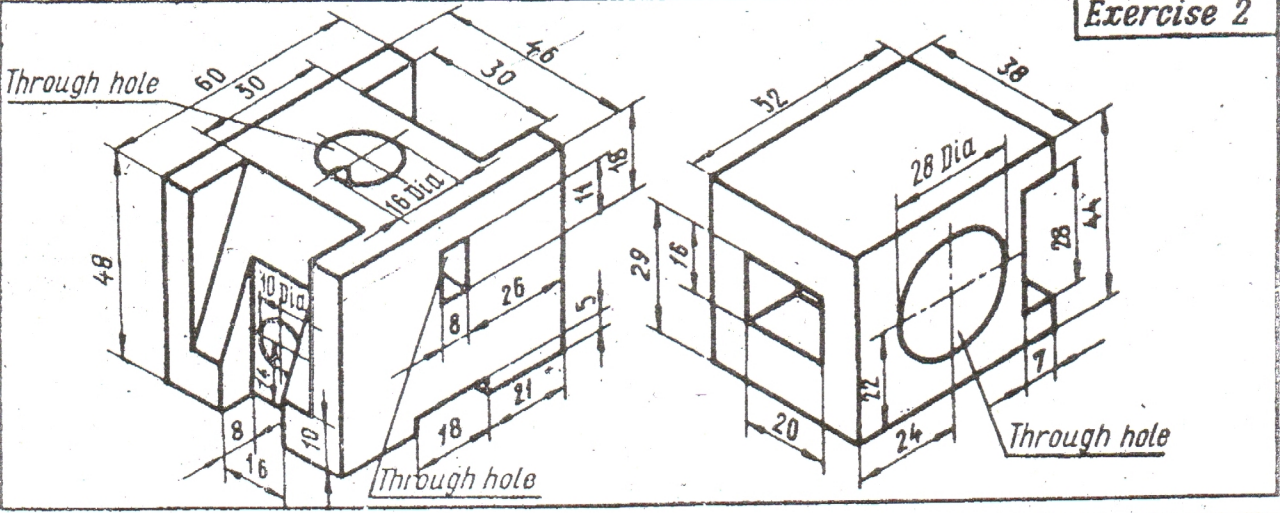

Exercise 3

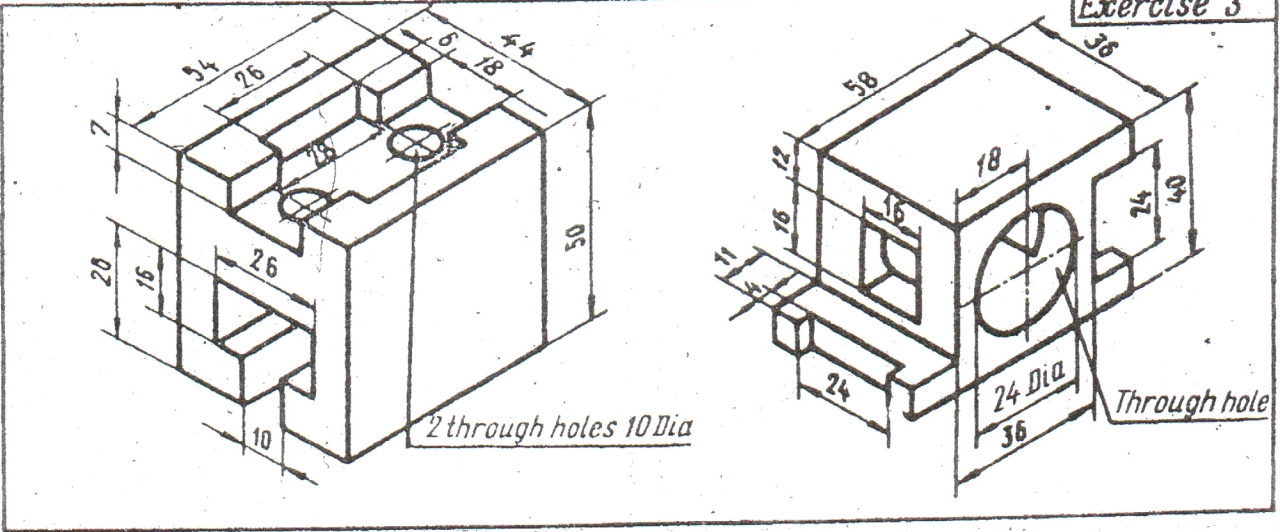

Exercise 7

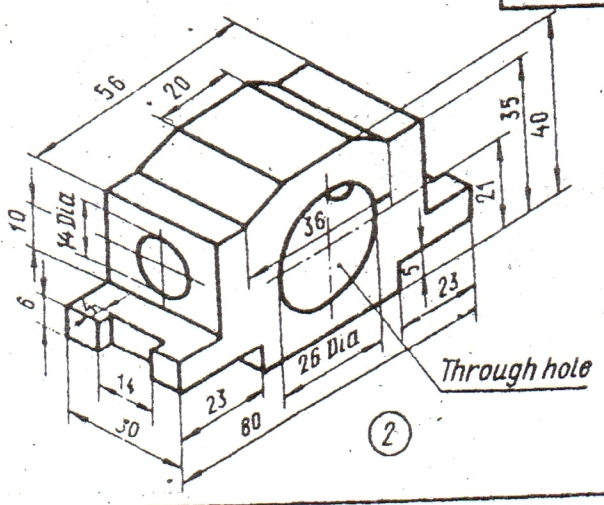
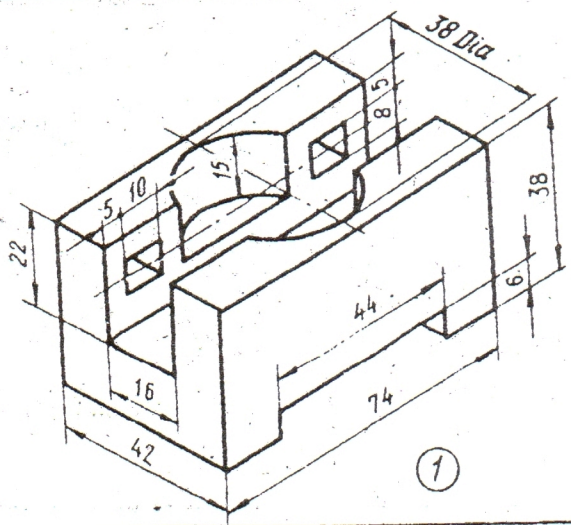

Through hole

Exercise 8

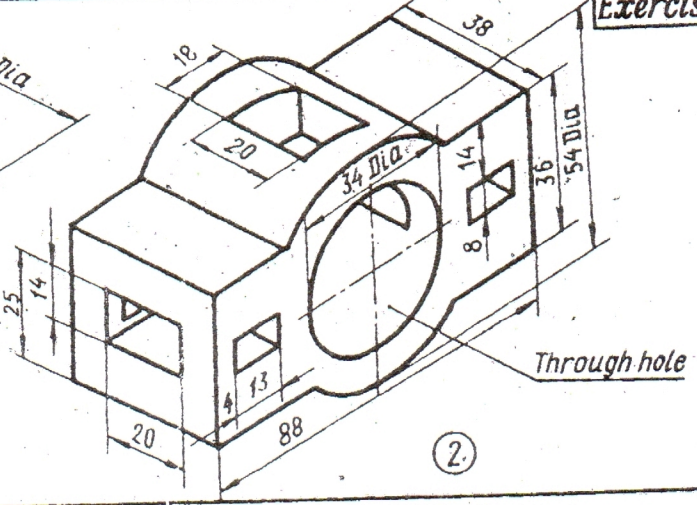
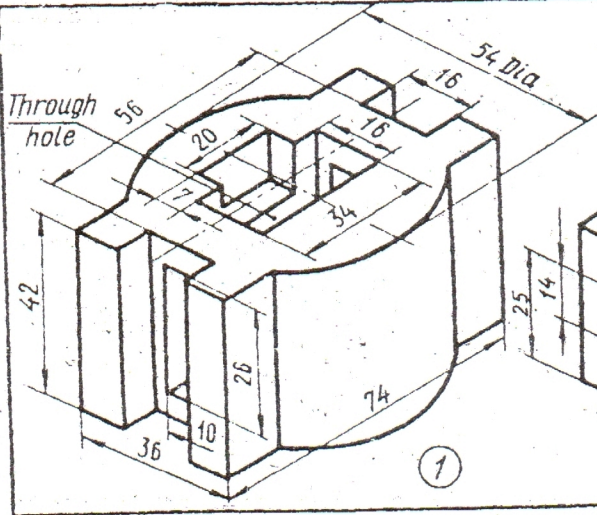

Through hole

Exercise 9

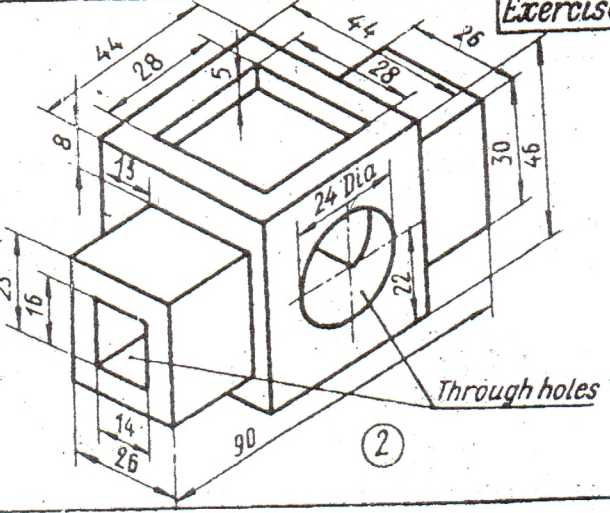
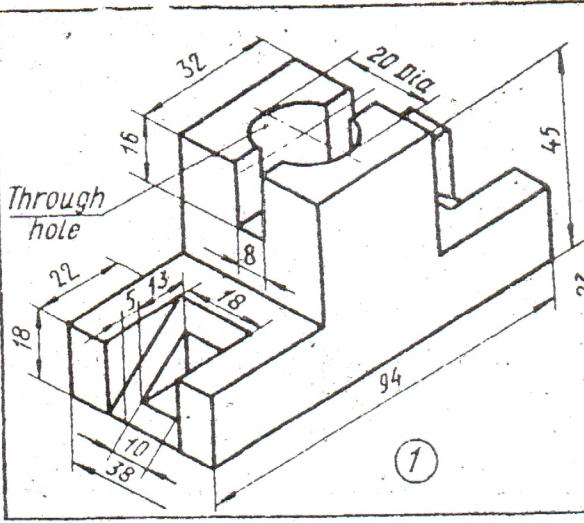

Through holes

Exercise 10

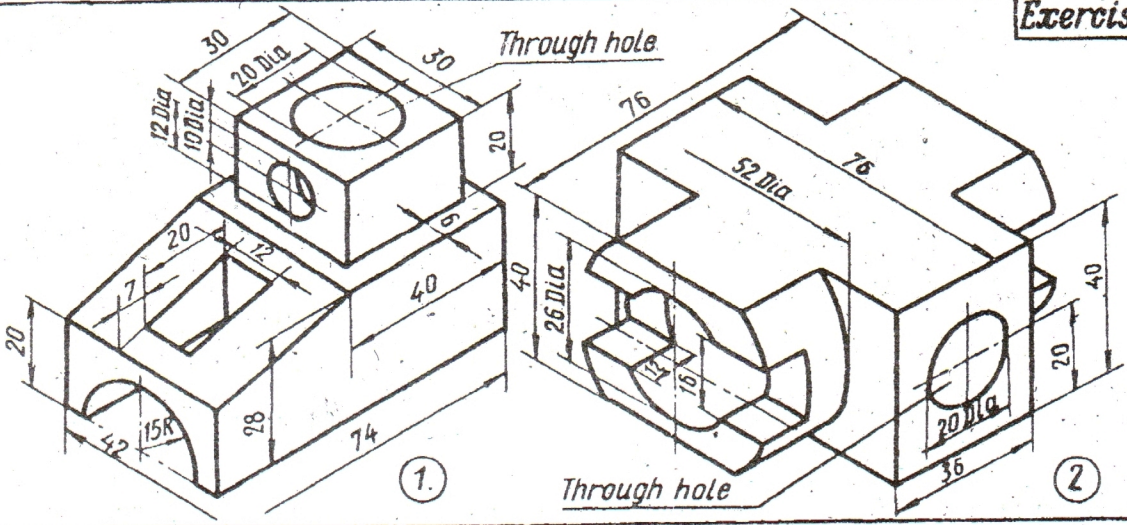

Exercise 11

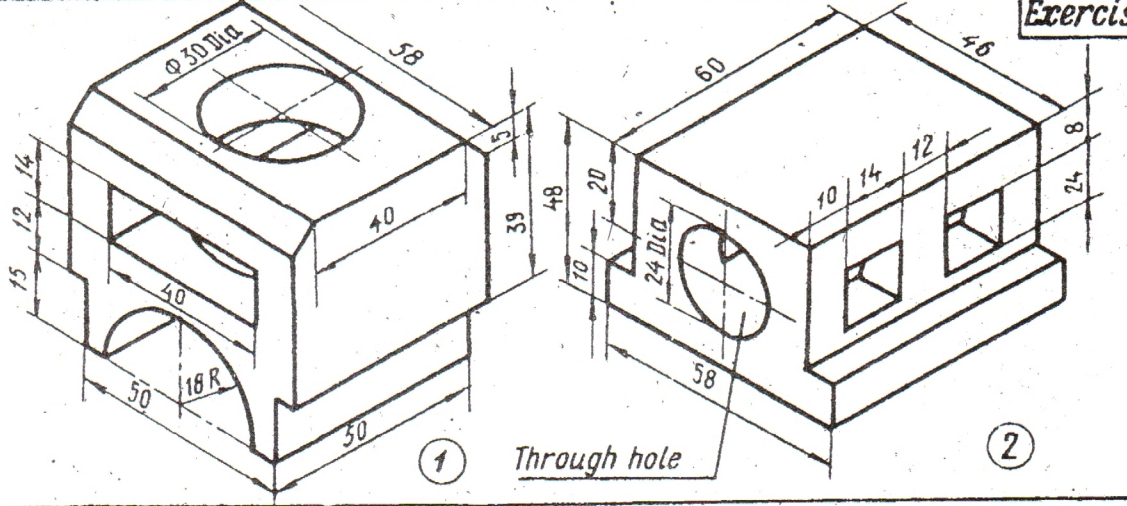

Exercise 12

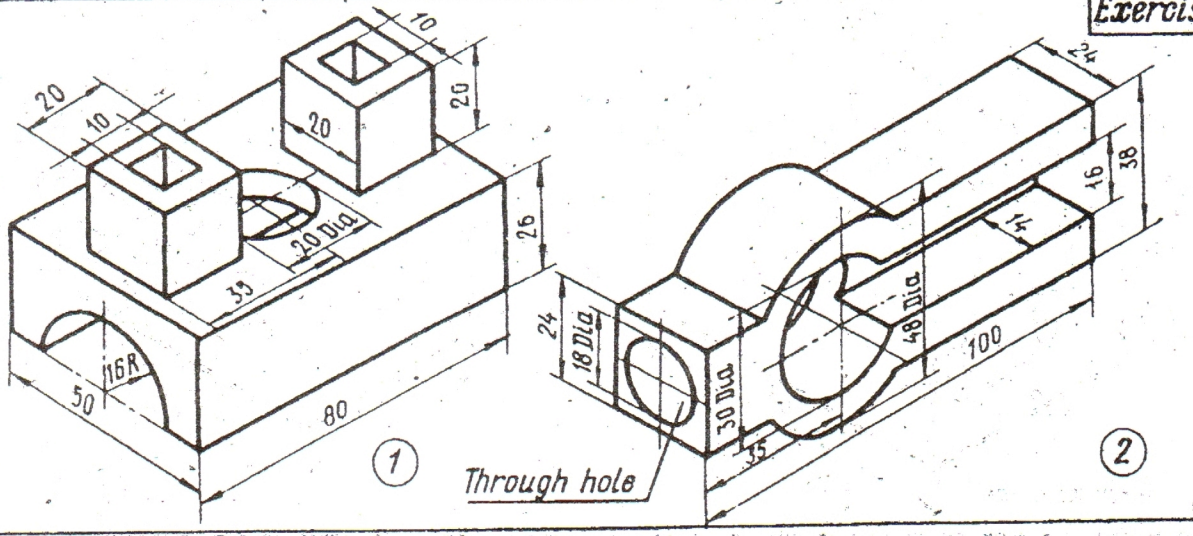

Exercise 16

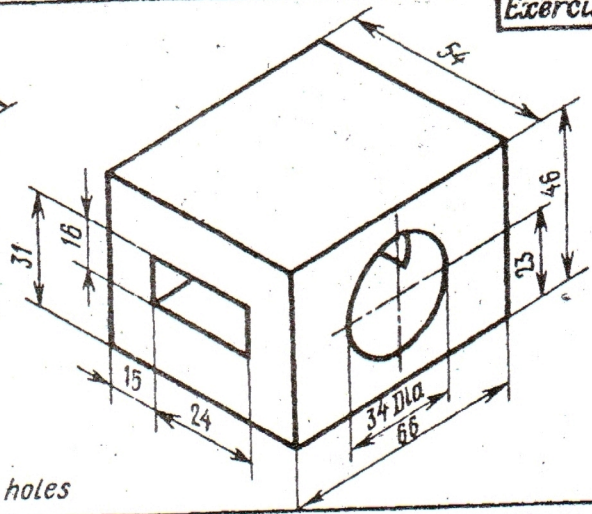
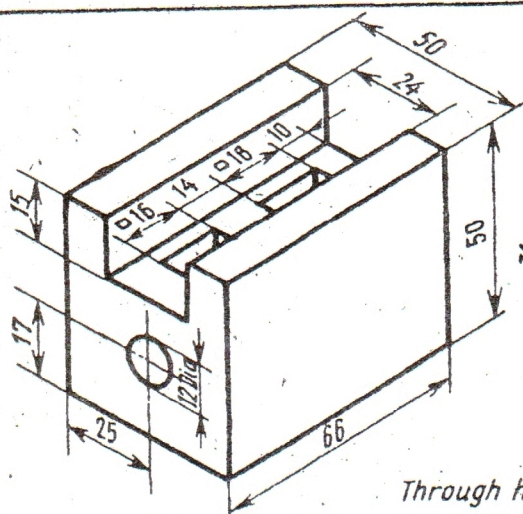

Through holes

Exercise 17

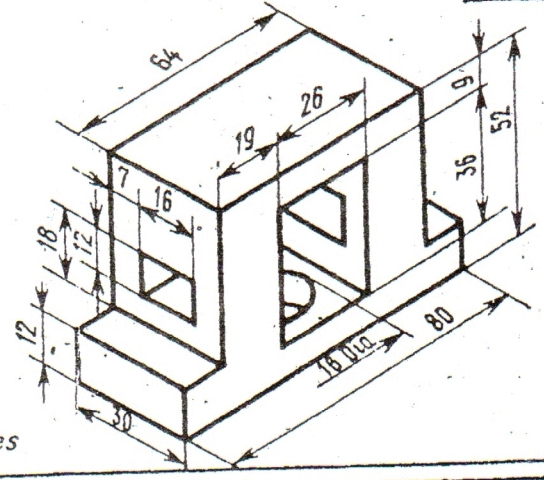
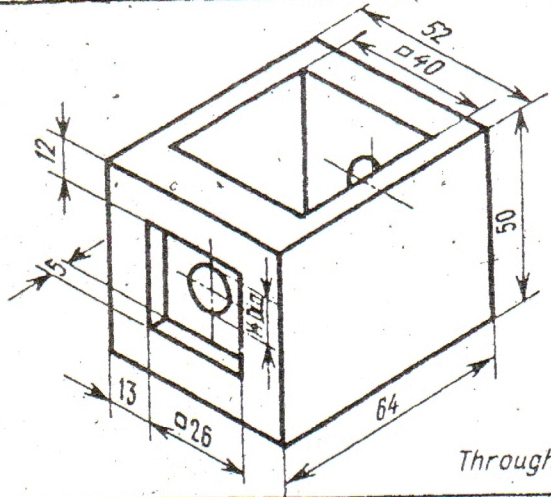

Through holes

Exercise 18

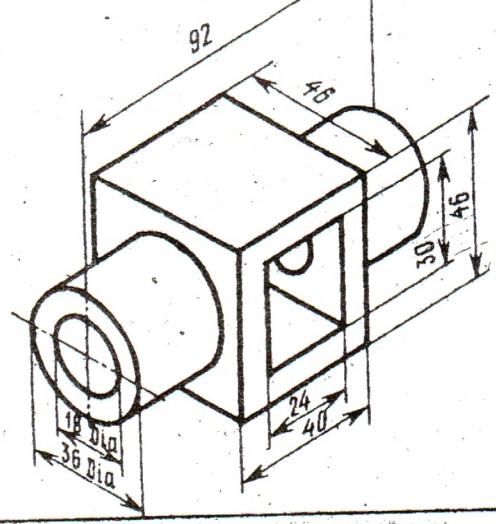
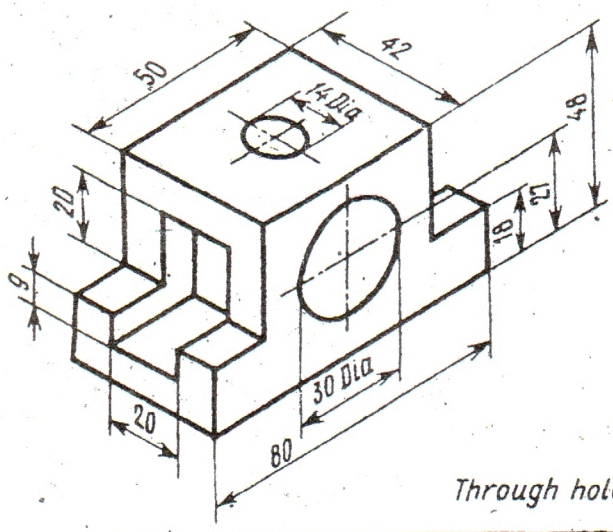

Through holes

Exercise 19

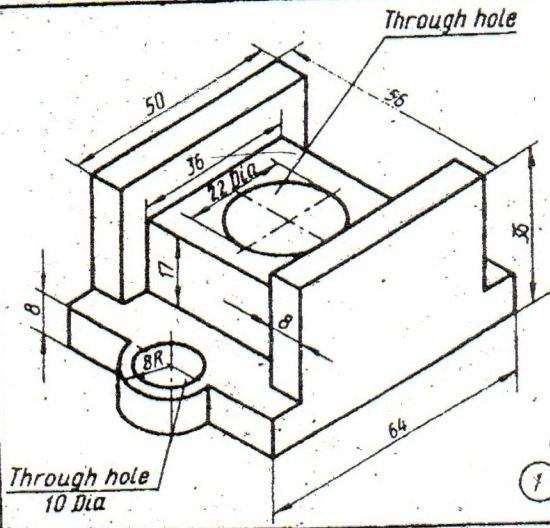

1

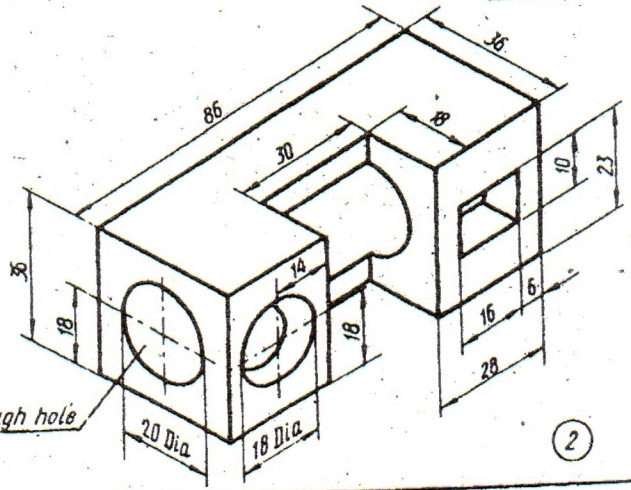

2

Exercise 20

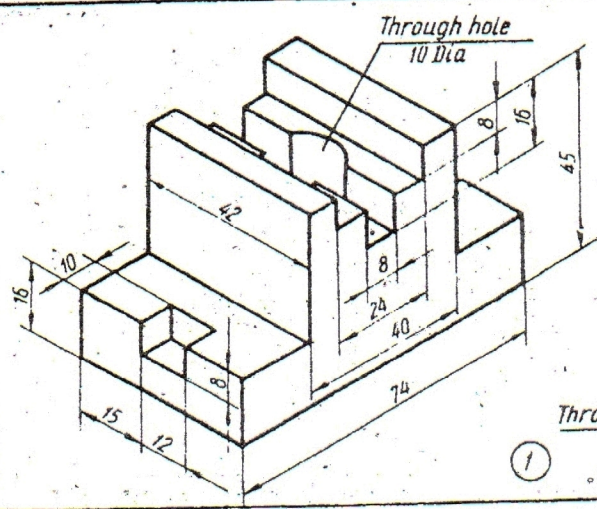

1

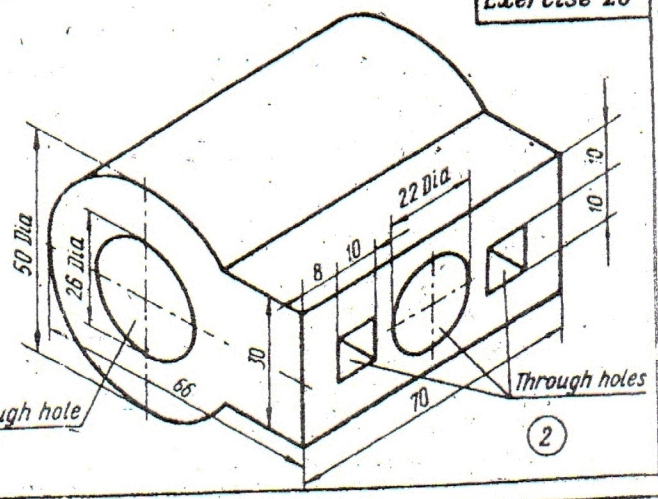

2

Exercise 21

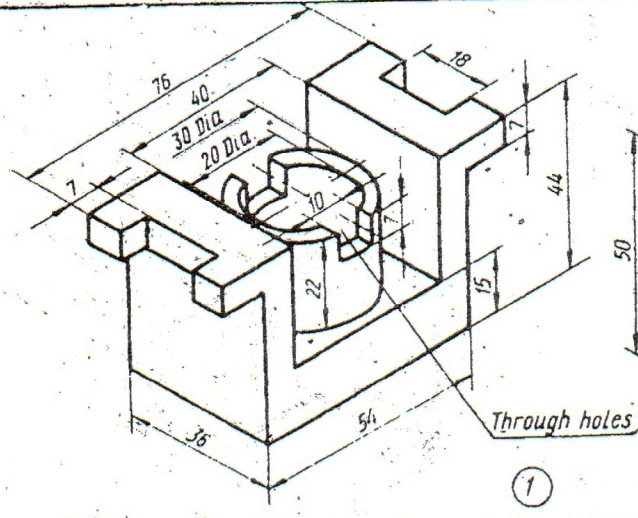

1

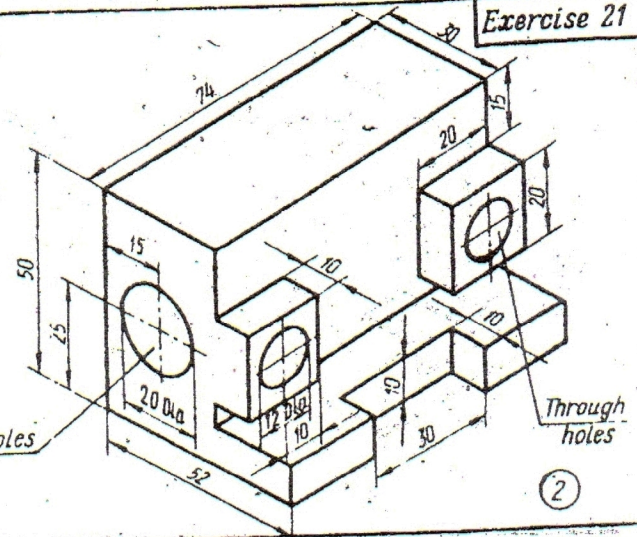

2

Exercise 1

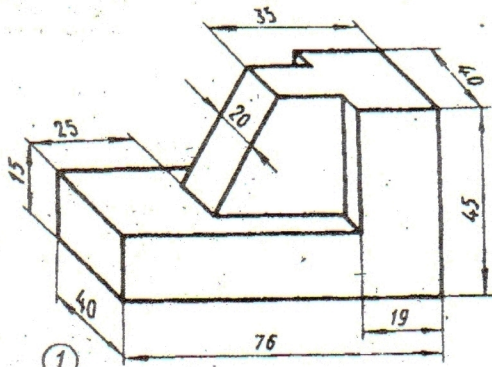

①

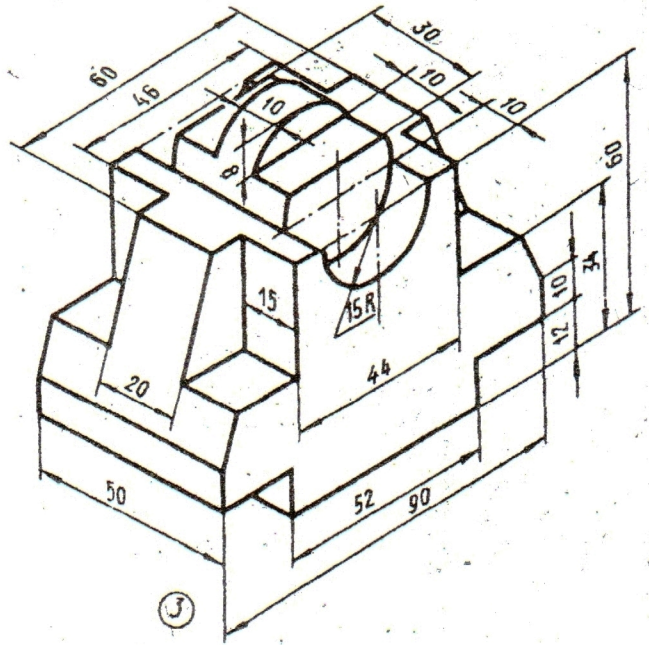

③

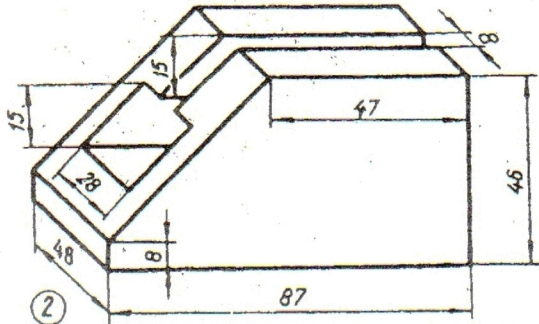

②

Exercise 2

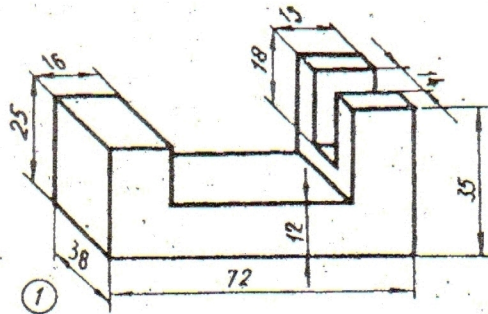

①

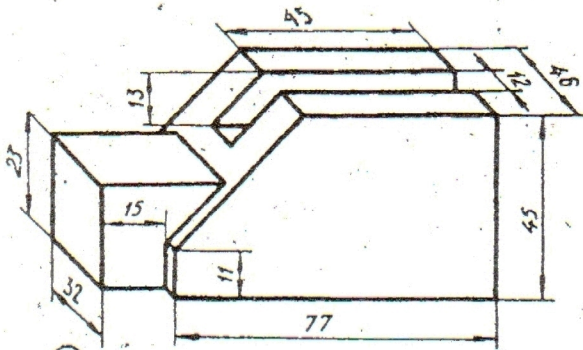

②

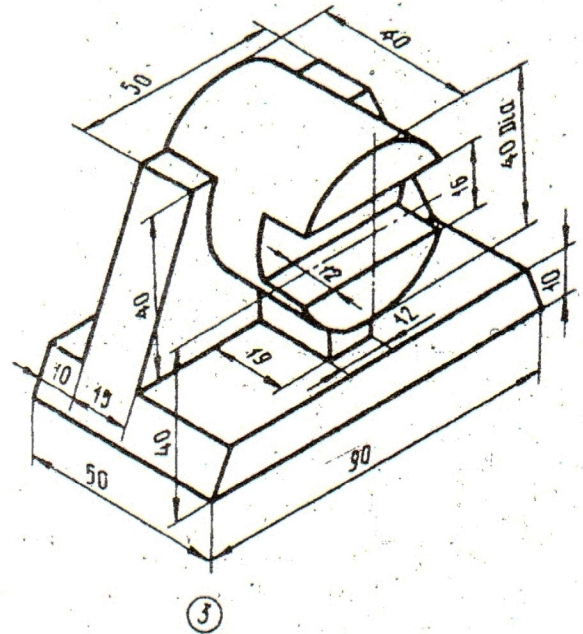

③

Exercise 3

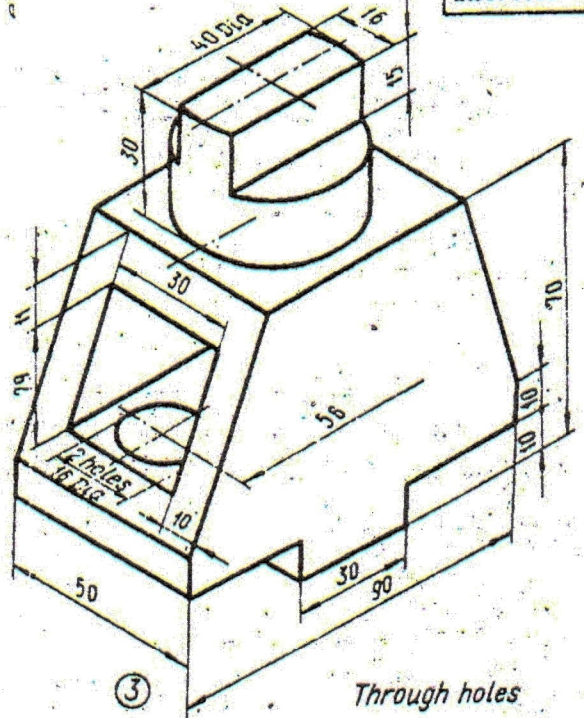
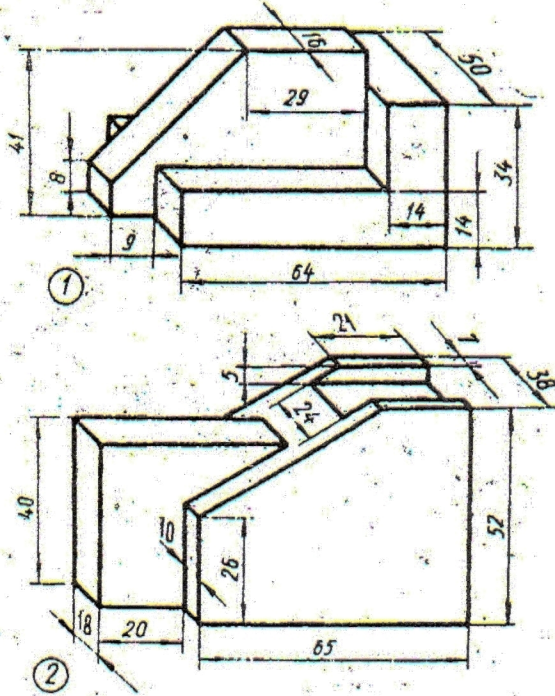
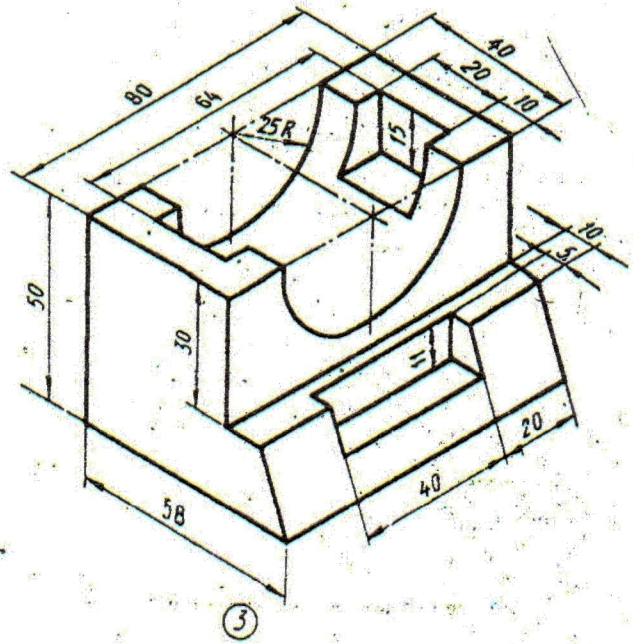
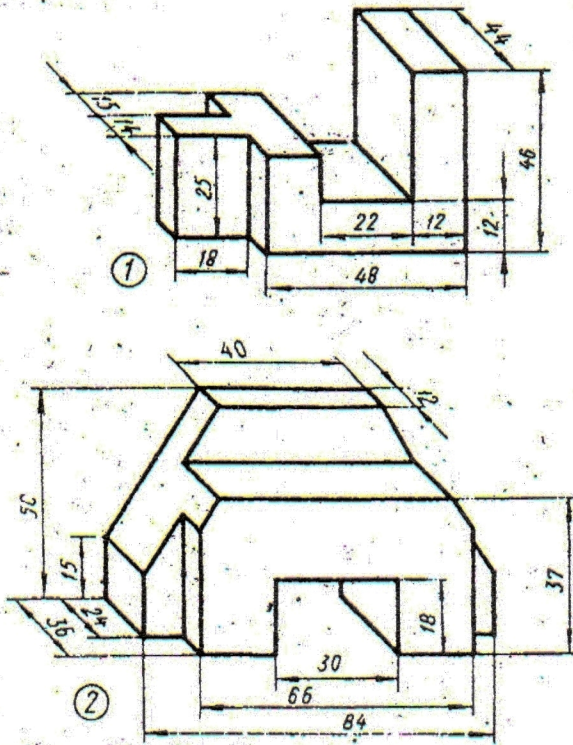

Exercise 4

Exercise 5

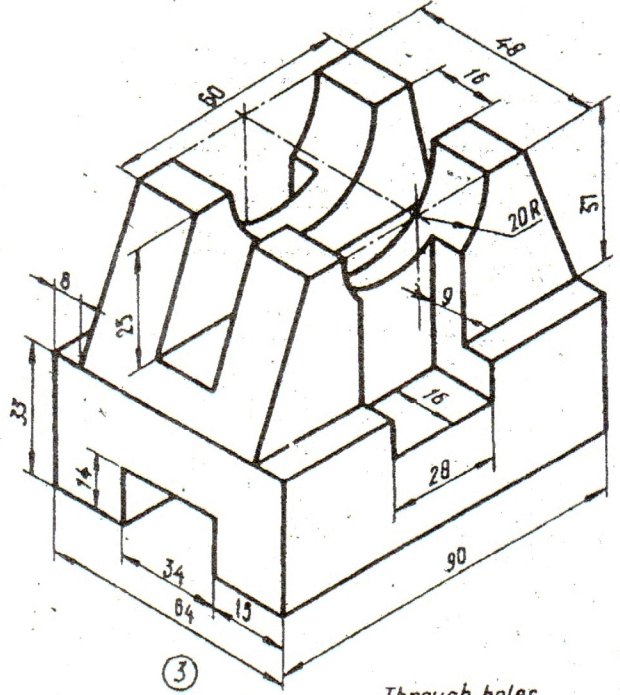
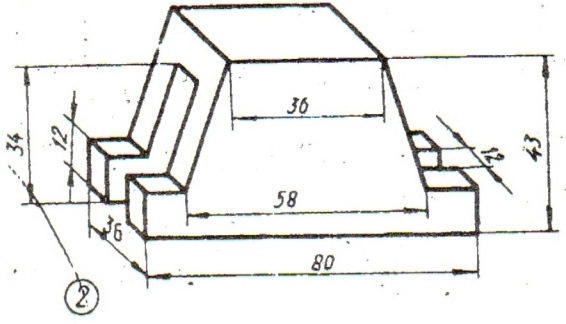
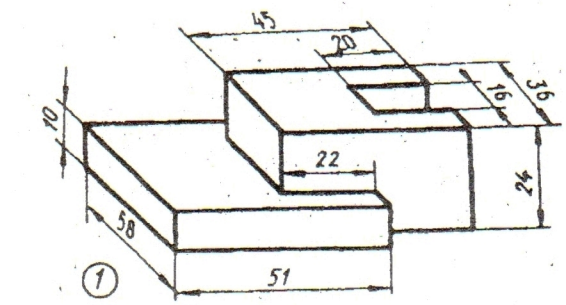

Through holes

Exercise 6

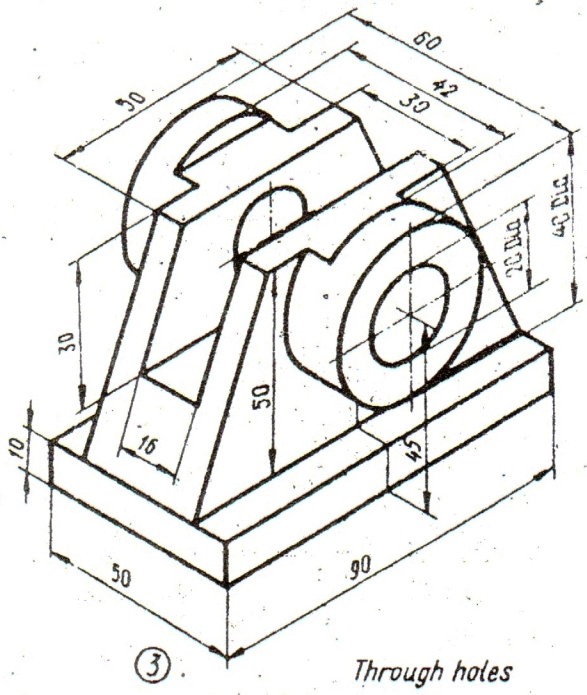
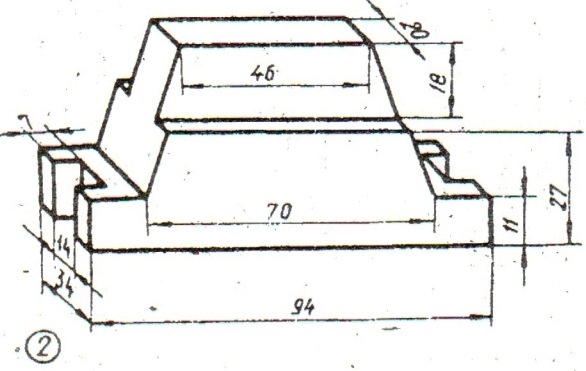
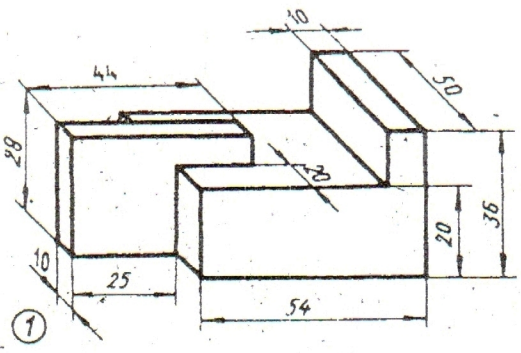

Through holes

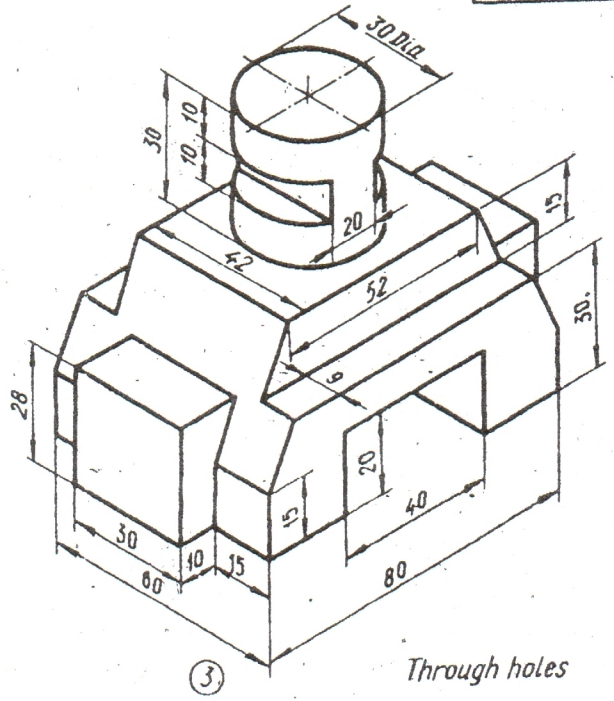
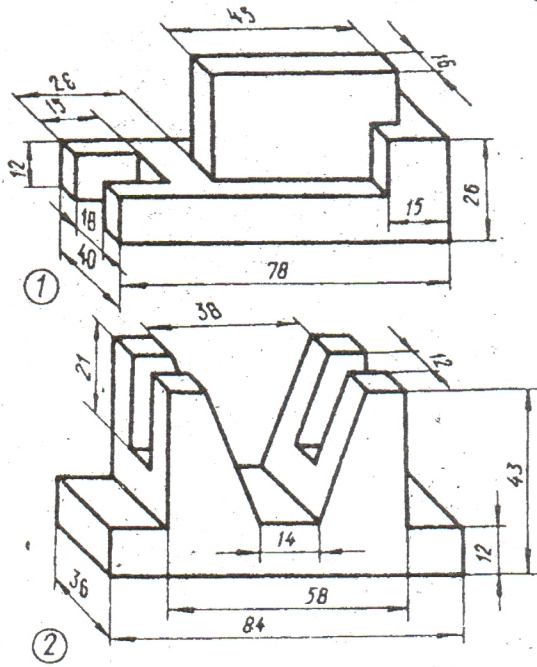

Through holes

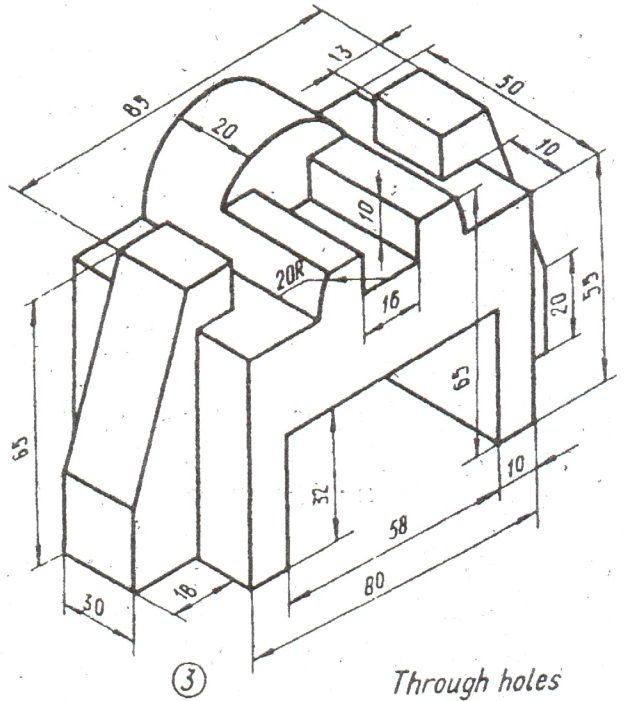
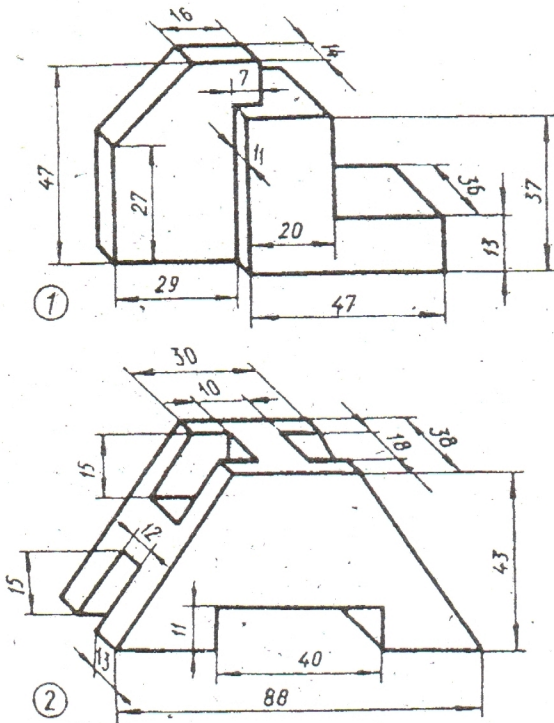

Through holes

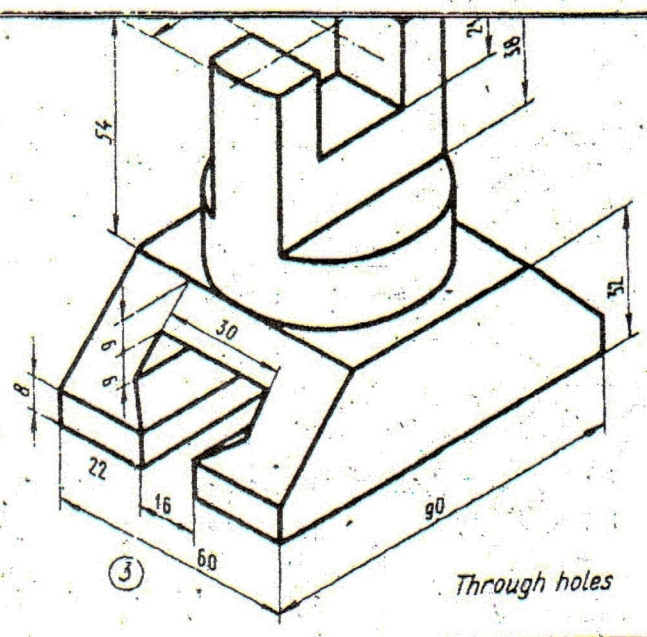
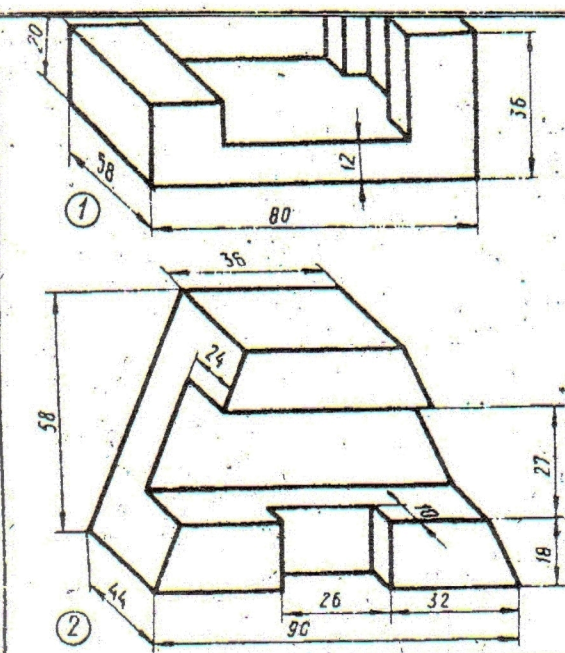

Through holes

Exercise 10

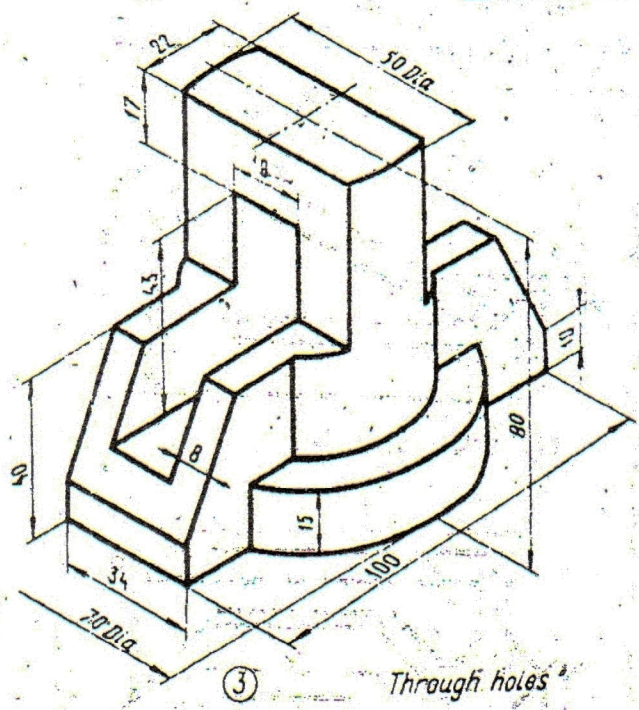
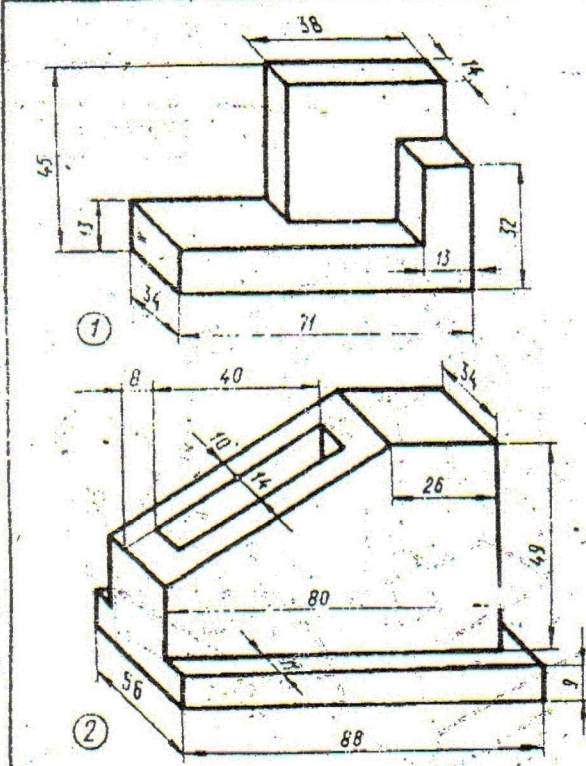

Through holes

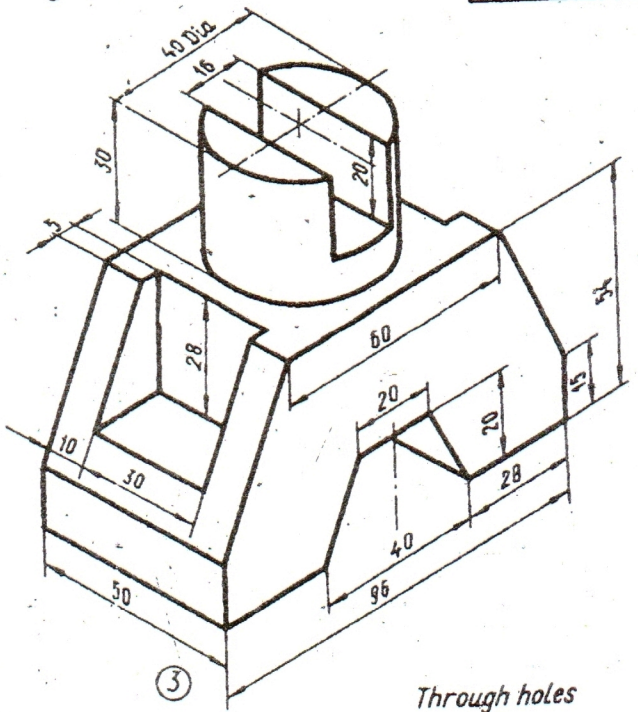
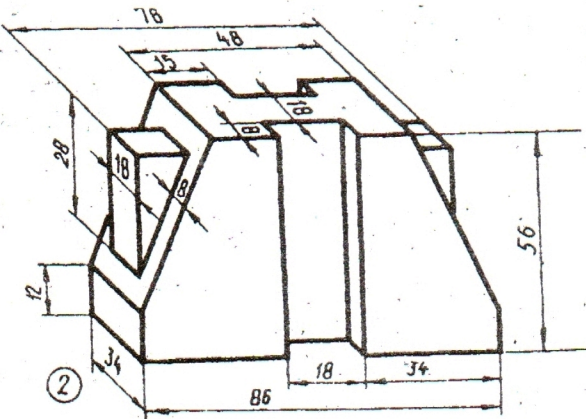
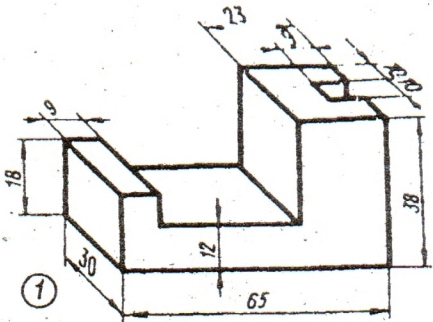

Through holes

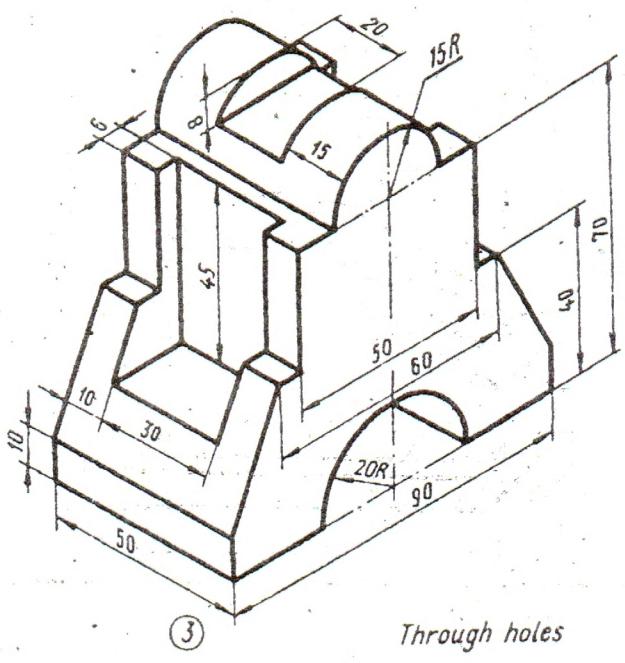
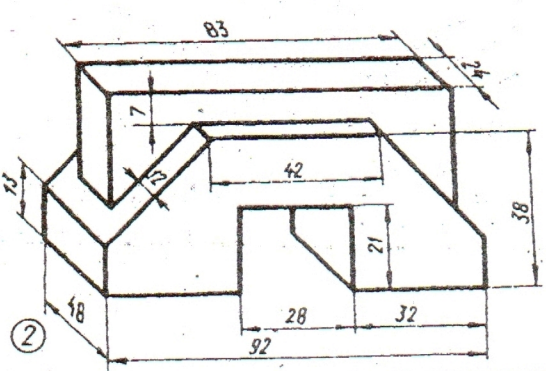
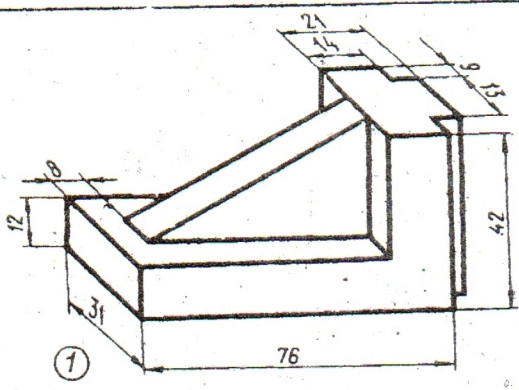

Through holes

Exercise 13

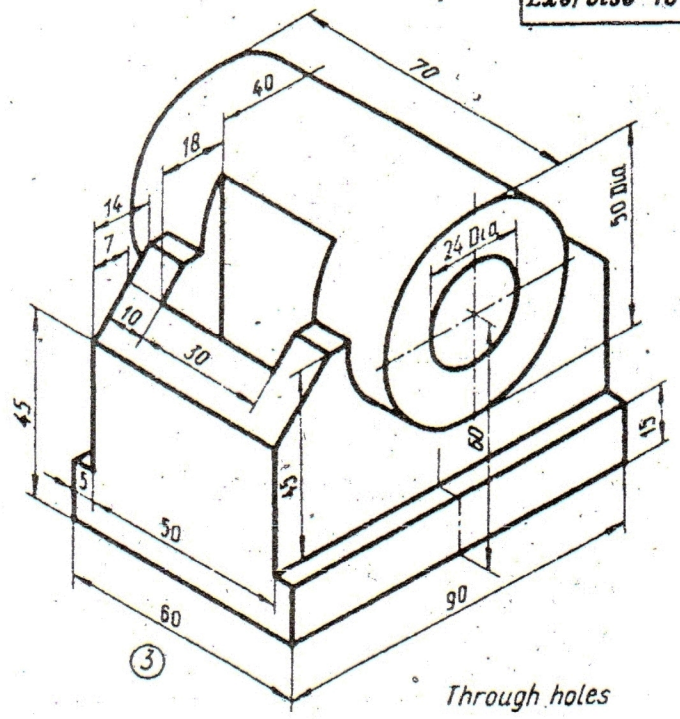
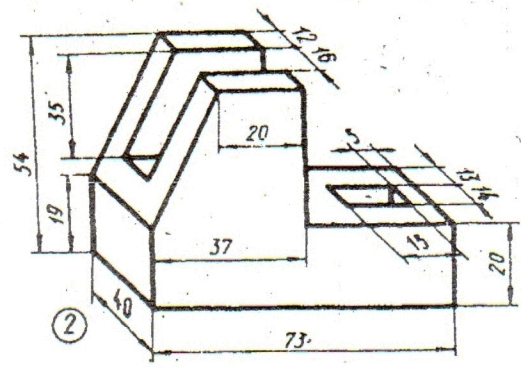
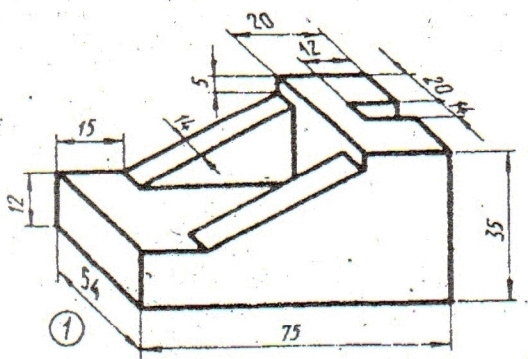

Through holes

Exercise 14

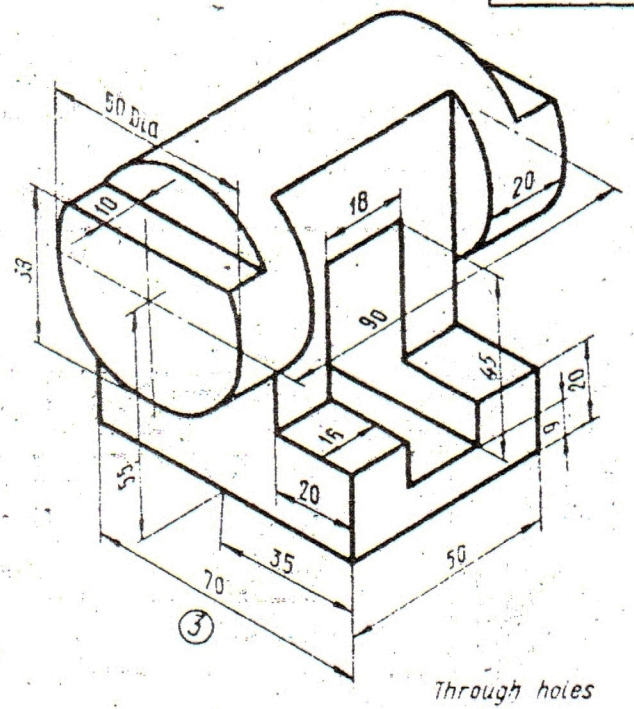
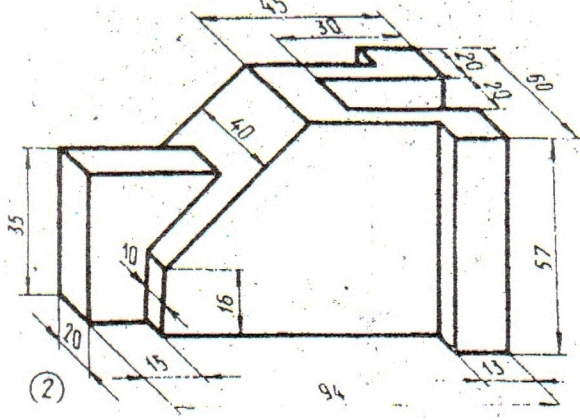
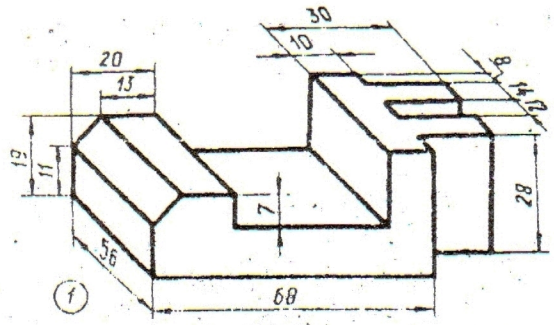

Through holes

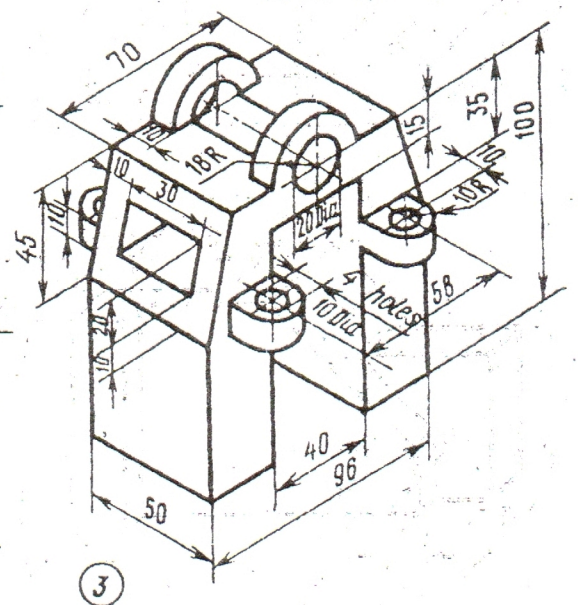
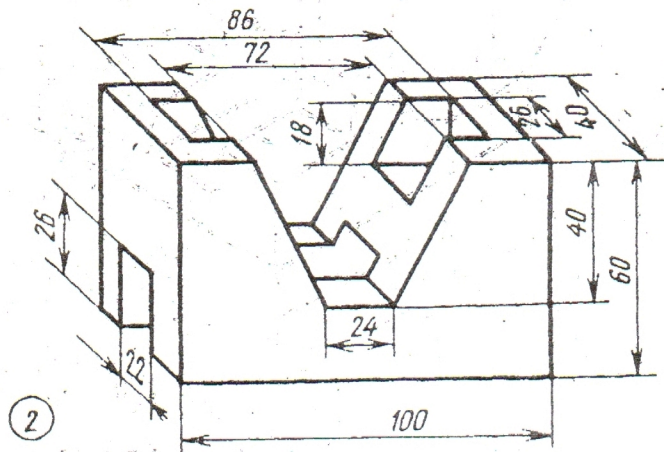
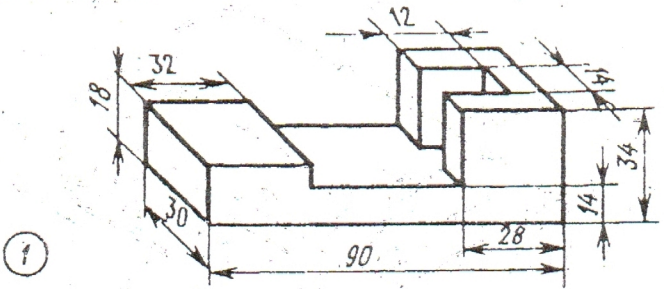
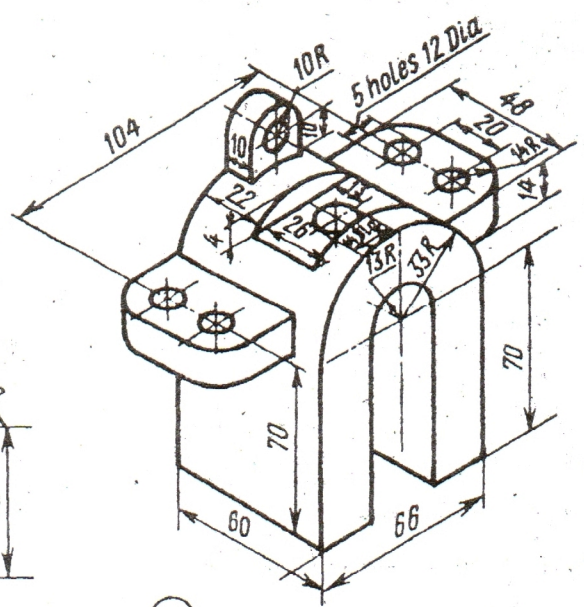
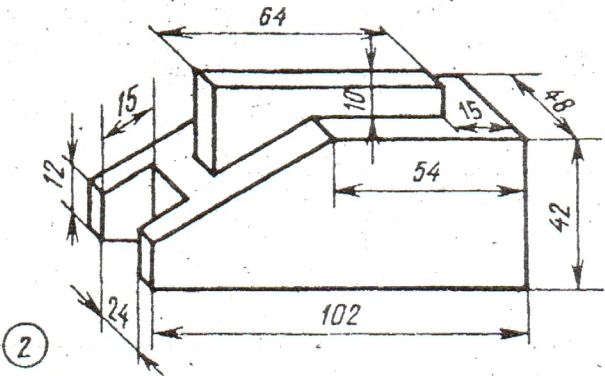
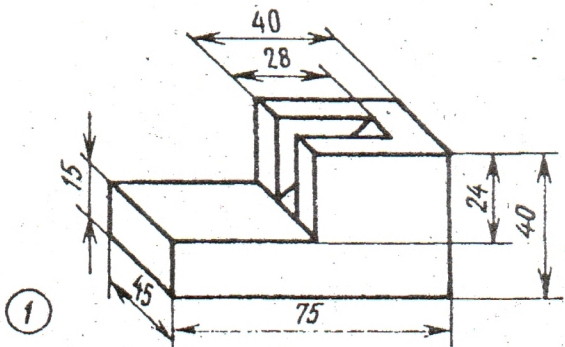

Exercise 17

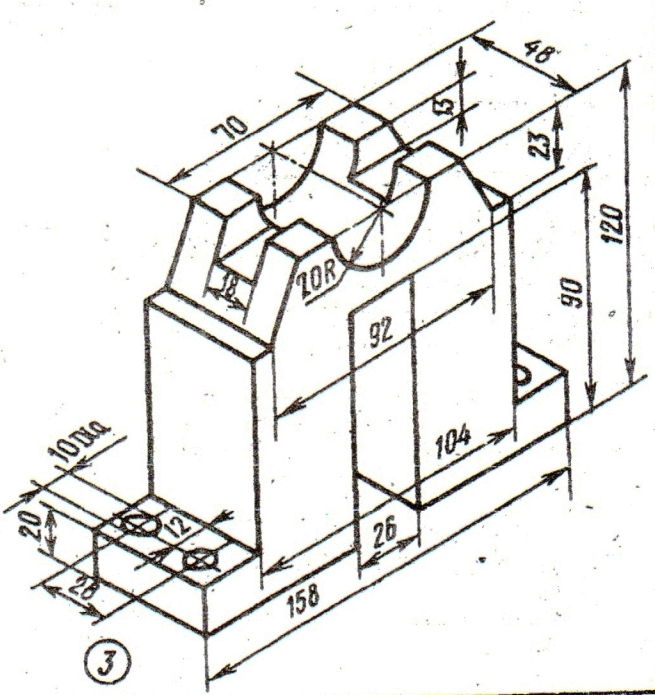
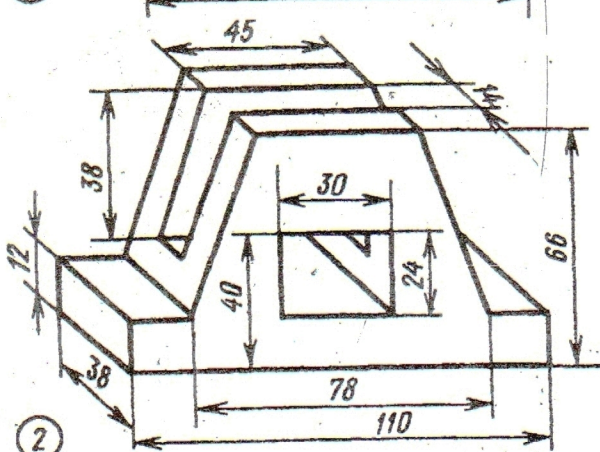
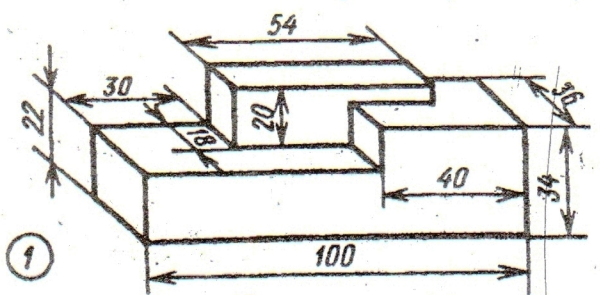

Exercise 18

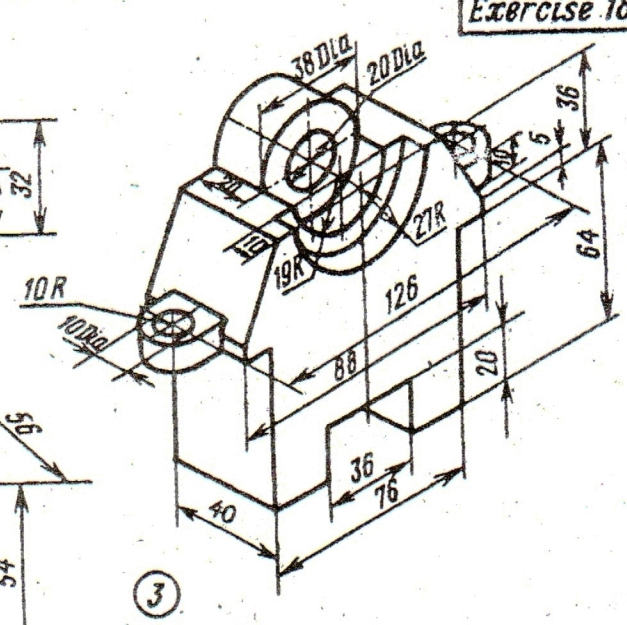
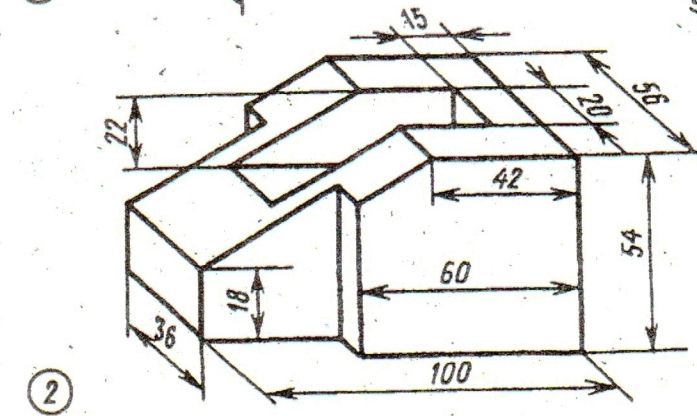
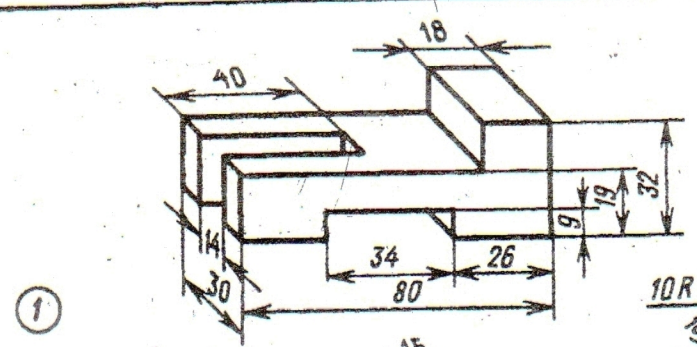

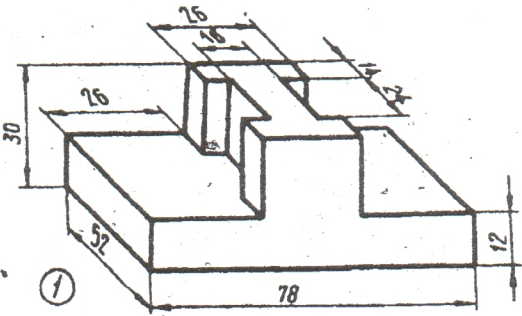

1

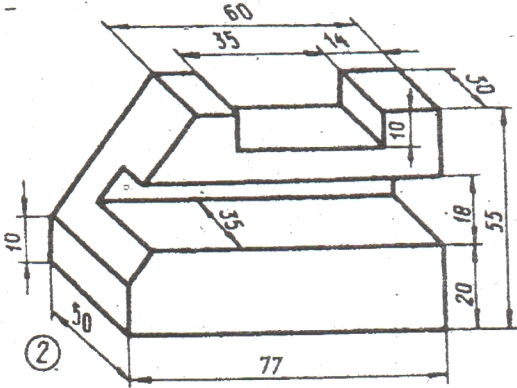

2

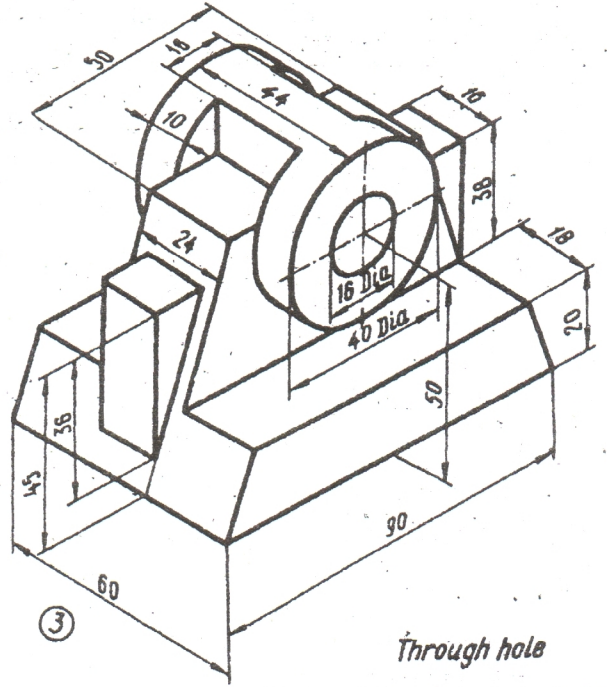

3

Through hole

Exercise 20

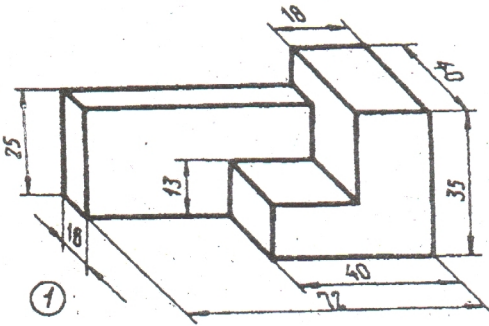

1

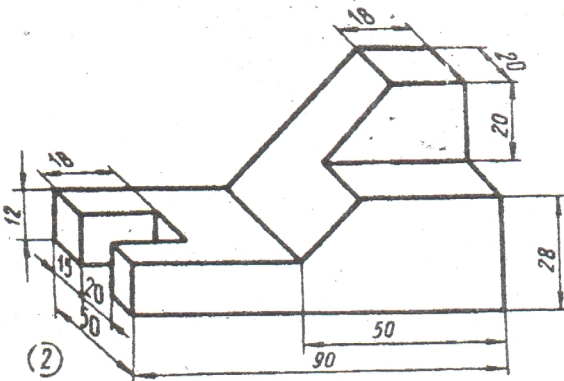

2

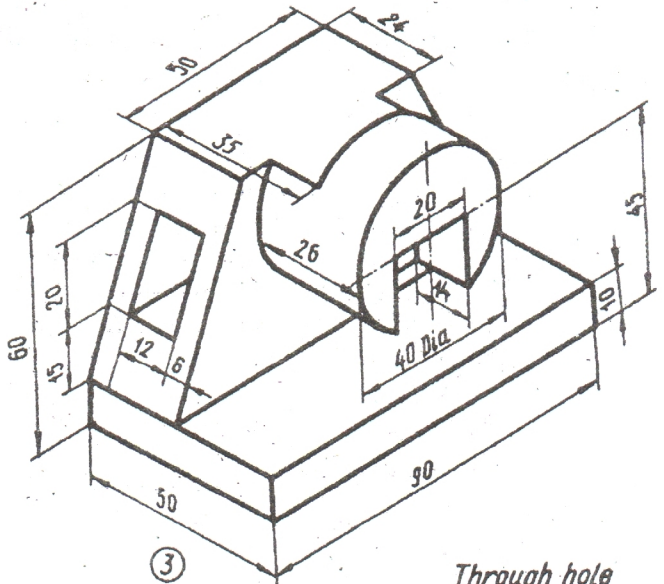

3

Through hole